



# Peterbilt 'BILL SIGNS TRUCKING'

07522 - 0389

© 1994 BY REVELL AG.

PRINTED IN W. GERMANY

**DEUTSCH: ACHTUNG:** Vor dem Zusammensetzen die Bauanleitung gut durchlesen. Jedes Teil ist nummeriert. Reihenfolge der Montageschritte beachten. Benötigte Werkzeuge: Messer und Feile zum Entfernen und Entgraten der Teile, Gummiband, Klebeband und Wäscheklammern zum Zusammenhalten der geklebten Einzelteile. Plastikteile in einer milden Waschmittellösung reinigen und an der Luft trocknen, damit der Farbanstrich und die Abziehbilder besser haften. Vor dem Ankleben prüfen, ob die Teile passen; Klebstoff sparsam auftragen. Chrom und Farbe an den Klebeflächen entfernen. Kleine Teile anstreichen, bevor sie vom Rahmen entfernt werden. Farben gut durchtrocknen lassen, erst dann den Zusammenbau fortsetzen. Jedes Abziehbildmotiv einzeln ausschneiden und ca. 20 Sekunden in warmes Wasser tauchen. Das Motiv an der bezeichneten Stelle vom Papier abschleiben und mit Löschpapier andrücken.

**ENGLISH: ATTENTION:** Carefully read instruction sheet before assembling. Each part is numbered. Consider succession of assembly steps. Required tools: knife and file to remove and trim parts; rubber band, adhesive tape and clothes pegs to hold parts after cementing. Wash plastic in mild detergent solution, rinse and let air dry for better paint and decal adhesion. Scrape chrome and paint at area to be glued: Paint small parts on runner before removing. Allow paint to dry thoroughly before continuing assembly. Cut out each decal one by one and dip it in warm water for approx. 20 secs.; slide decal from the paper at the marked position and dab with blotting-paper.

**FRANCAIS: ATTENTION:** lire soigneusement la fiche d'instructions avant d'assembler. Chaque pièce est numérotée. Suivre la succession des étapes de montage. Outils nécessaires: couteau et lime pour détacher et ébarber les pièces, élastiques, papier adhésif et pinces à linge pour maintenir ensemble les pièces après collage. Laver le plastique dans une solution détergente légère, rincer et laisser sécher à l'air libre pour une meilleure adhérence de la peinture et des décals. Ajuster les pièces ensemble avant de coller. Employer la colle Revell pour plastique exclusivement. Utiliser très peu de colle à chaque fois. Gratter le chrome ou la peinture sur les surfaces à coller. Peindre les petites pièces sur le support avant de les détacher. Laisser la peinture sécher totalement avant de continuer l'assemblage. Découper chaque décal séparément et le plonger dans l'eau chaude environ 20 secondes. Faire glisser le décal du papier à l'endroit du décor et tamponner avec du papier buvard.

**NEDERLANDS: OPGELET:** alvorens te beginnen met het in elkaar zetten, eerst de handleiding goed doorlezen. Elk onderdeel is genummerd. Aandacht besteden aan de volgorde van montage. Het benodigde gereedschap: mesje en vijl voor het verwijderen en het afbramen van de onderdelen, elastiek, plakband en wasknijpers gebruiken voor het bij elkaar houden van de gelijmdede onderdelen. De plastic onderdelen met een zacht wasmiddel schoonmaken en laten drogen zodat de verf en de transfers beter hechten. Alvorens te lijmen, eerst vaststellen of de onderdelen

passen; de lijm zuinig opbrengen. Chrom en verf van de op elkaar te lijmen delen verwijderen. Kleine onderdelen verven vóór deze van het gietraam verwijderd worden. De verf goed laten drogen en eerst dan verder gaan met de bouw. Elk transfer apart uitknippen en ca. 20 seconden in lauw/warm water leggen. Het transfer op de juiste plaats van het papier schuiven op het model en met vloeipapier aandrukken.

**SVENSKA: VIKTIGT:** Läs noggrant igenom instruktionerna innan du börjar bygga. Varje del är numrerad. Tänk igenom ordningsföljden för de olika momenten. Följande verktyg krävs: kniv och fil för att ta loss och putsa detaljerna, gummiband, tejp och klädnyor för att hålla detaljerna på plats medan limmet torkar. Tvätta alla plastdetaljerna i mild tvålösning, skölj och låt lufttorka för att få färg och dekaler att fästa bättre. Proppassa alltid detaljerna innan du limmar. Använd endast Revells plastlim. Använd sparsamt med lim. Skrapa bort krom och färg från den yta som ska limmas: måla smådetaljerna innan du skär loss dem. Låt all färg torka ordentligt innan du fortsätter byggandet. Skär ut varje dekal för sig och blöt den i ljummet vatten i ungefär 20 sekunder, och låt dekalen glida av papperet och ner på det markerade läget: sug sedan försiktigt upp det mesta vatnet med läskpapper eller en tygtrasa.

**ITALIANO: Attenzione:** Leggere attentamente le istruzioni prima dell'assemblaggio. Ogni pezzo è numerato. Tener presente la successione delle fasi di assemblaggio. Attrezzi necessari: coltello e lima per rimuovere e rifinire le parti elastico nastro adesivo e spilli per tenere le parti dopo averle incollate. Lavare la plastica con un detergente delicato, sciacquare e lasciar asciugare all'aria per una migliore adesione della vernice e delle 'decals'. Accoppiare le parti da incollare. Usare solamente 'Revell plastic cement'. Usare poco collante. Grattare la cromatura e la vernice nei punti da incollare. Dipingere i piccoli accessori sul supporto prima di rimuoverli. Far seccare bene la vernice prima di continuare nell'assemblaggio. Ritagliare una per una le 'decal' ed immergerle in acqua tiepida per circa 20 secondi. Applicare ogni 'decal' nella posizione segnata e tamponare con della carta assorbente.

**ESPAÑOL: ATENCION:** cuidadosamente lean la hoja de instrucciones antes del montaje. Cada pieza es numerada, consideren la sucesion de las operaciones de montaje. Herramientas requeridas: cuchilla y lima para quitar y desbarbar las piezas, banda de caucho, cinta adhesiva y pinzas para sujetar las piezas, despues de engomarias. Lavar el plastico en solucion detergente suave, aclarar y dejar que se seque al aire para una mejor adhesion de la pintura y la calcomania. Adaptar las piezas bien juntas antes de encolar. Solamente utilizar pegamento plastico Revell. Utilizar el pegamento cuidadosamente y sin exceso. Raspar el cromado y la pintura en la zona que ha de ser encolada: Pintar las piezas pequeñas giratorias antes de sacarlas. Dejar que la pintura se seque totalmente antes de continuar el montaje. Cortar cada calcomania una por una y sumergirla en agua caliente durante aproximadamente 20 segundos. Deslizar la calcomania del papel en la posición marcada y golpearla suavemente con el papel secante.



Kleben  
Glue  
A coller  
Lijmen  
Limmas  
Incollare  
Engomar

Nicht kleben.  
Don't glue.  
À ne pas coller.  
Niet lijmen.  
Timmas ej.  
Non incollare.  
No engomar.

Anzahl der Arbeitsgänge.  
Number of working steps.  
Nombre d'étapes de travail  
Het aantal der bouwhandelingen.  
Antal arbetsmoment.  
Numero di passaggi.  
Numero de operaciones de trabajo.

Wahlweise  
Optional  
Facultatif  
Ter keuze  
Valfritt  
Facoltativo  
Opcional

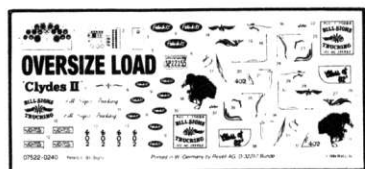

Abziehbild in Wasser einweichen und anbringen.  
Soak and apply decals.  
Mouiller et appliquer les décals.  
Transfer in water even laten weken en opbrengen.  
Blöt och fäst dekaler.  
Immergere in acqua ed applicare decal.  
Remojar y aplicar las calcomanias.

Abbildung zusammengebauter Teile.  
Shown assembled.  
Vu assemblé.  
Afbeelding van een gebouw onderdeel.  
Visas hopsatt.  
Figura ensamblada.  
Presentado montado.

Klarsichtteile  
Clear parts  
Pièces transparentes  
Transparante onderdelen  
Genomskinliga detaljer  
Parte trasparente  
Limpiar las piezas

<b>A</b> BLACK <b>SCHWARZ 302</b> NOIR ZWART SVART NERO	<b>60% B 40%</b> BLACK METALLIC GREY <b>SCHWARZ 7 EISENFARBIG 91</b> NOIR GRIS METALLIQUE ZWART + IJZERKLEUR SVART JÄRNGRÅ NERO FERRO	<b>C</b> BLACK <b>SCHWARZ 7</b> NOIR ZWART SVART NERO	<b>D</b> ANTHRACITE <b>ANTHRAZIT 9</b> ANTHRACITE ANTHRACIET ANTRACIT ANTRACITE	<b>E</b> WHITE <b>WEISS 301</b> BLANC WIT VIT BIANCO	<b>F</b> DARK BROWN <b>DUNKELBRAUN 91</b> MARRON FONCE DONKERBRUIN MÖRKBRUN MARRONE SCURO	<b>G</b> BEIGE <b>BEIGE 314</b> BEIGE BEIGE BEIGE BEIGE	<b>H</b> FIERY RED <b>FEUERROT 330</b> ROUGE VERMILLON VUURROOD ELDRÖD ROSSO ACCESO
<b>I</b> METALLIC GREY <b>EISENFARBIG 91</b> GRIS METALLIQUE IJZERKLEUR JÄRNGRÅ FERRO	<b>J</b> ALUMINIUM <b>ALUMINIUM 99</b> ALUMINIUM ALUMINIUM ALUMINIUM ALUMINIUM	<b>K</b> SILVER <b>SILBER 90</b> ARGENT ZILVER SILVER ARGENTO	<b>L</b> CLEAR ORANGE <b>KLAR ORANGE 730</b> CLAIRE ORANGE DOORZICHTIG ORANJE KLAR ORANGE CHIARO ARANCIONE	<b>M</b> LIGHT GREY <b>HELLGRAU 371</b> GRIS CLAIR VAALGRIS LJUSGRÅ GRIGIO CHIARO	<b>N</b> GOLD <b>GOLD 94</b> COULEUR OR GOUD GULD ORO	<b>O</b> ORANGE <b>ORANGE 30</b> ORANGE ORANJE ORANGE ORANCIO	<b>P</b> MATT BLACK <b>MATT SCHWARZ 9</b> NOIR MAT MAT ZWART MATT ZWART NFRO SMORTO

Dieser Bausatz wurde in mehrfachen Qualitäts- und Gewichtskontrollen auf Vollständigkeit überprüft. Reklamationen können nur bearbeitet werden, wenn die Bauanleitung und das aus der Kartonage ausgeschnittene EAN-Strichcode-Feld eingeschickt werden. Einzelteile aus unseren Bausätzen für Umbauten usw. liefern wir mit Rechnung per Nachnahme. Unsere Adresse: Revell AG, Abteilung X, Henschelstr. 20-30, 32257 Bünde.

This model kit underwent various quality and weight controls to assure its completeness. Queries can only be processed when the building instructions are sent to Revell together with the EAN-Code of the product which is to be cut out from the packaging. Individual components of our model kits for conversion purposes can be ordered C.O.D. Write to: Revell AG, Department X, Henschelstr. 20-30, D-32257 Bünde.

L'intégralité des pièces de ce modèle réduit a été vérifiée au cours de plusieurs contrôles de qualité et de poids. Des réclamations ne peuvent être prises en considération que si le guide de montage ainsi que le code à barres EAN découpé du cartonage nous soient envoyés. Des pièces détachées de nos modèles réduits pour transformations, etc. sont livrées suivant facture contre remboursement. Notre adresse: Revell AG, département X, Henschelstr. 20-30, D-32257 Bünde.

Deze bouwdoos is bij meerdere kwaliteits- en gewichtskontroles op volledigheid gecontroleerd. Klachten kunnen alleen dan in behandeling worden genomen, wanneer de bouwvoorwaarden en het uit de kartonnen doos uitgeknipte veld met de EAN barcode worden opgestuurd. Losse onderdelen uit onze bouwdozen voor ombouw en dergelijke leveren wij met factuur onder rembours. Ons adres: Revell AG, Afdeling X, Henschelstr. 20-30, D-32257 Bünde.

07522

■ = Nicht benötigte Bauteile.  
= Parts not used.  
= Pièces non utilisées.  
= Niet benötigde onderdelen.  
= Delar som inte används.  
= Partii non usate.  
= Piezas no utilizadas.

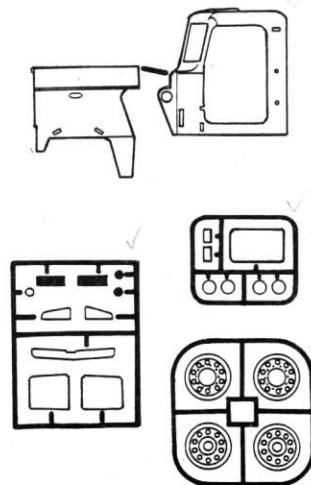
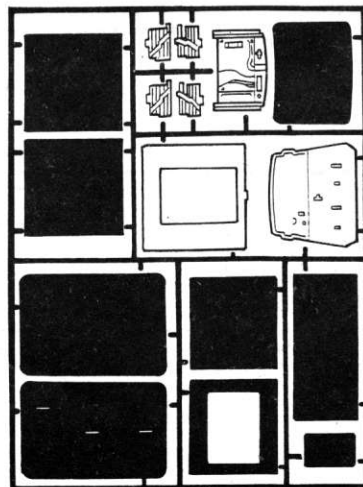
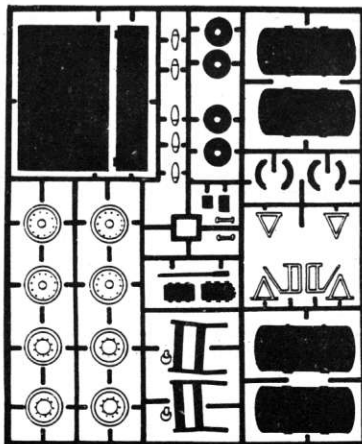
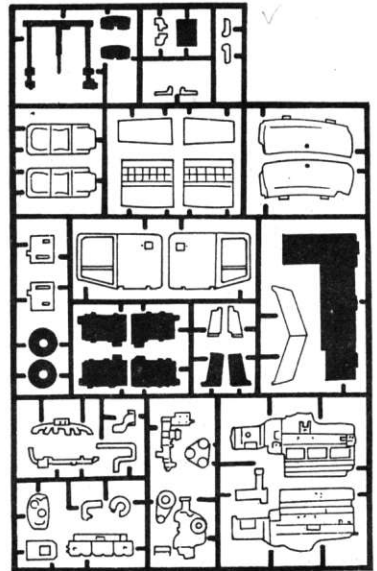
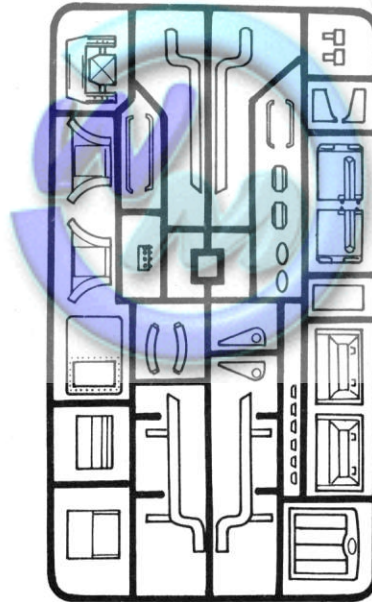
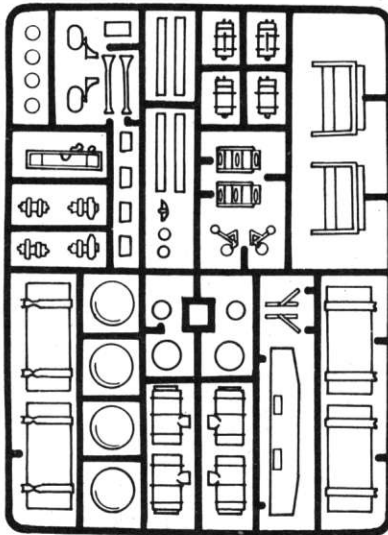
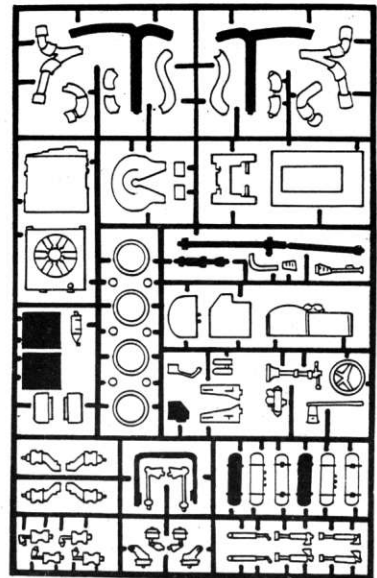
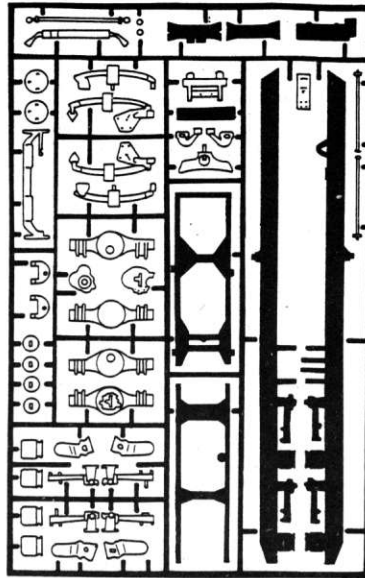
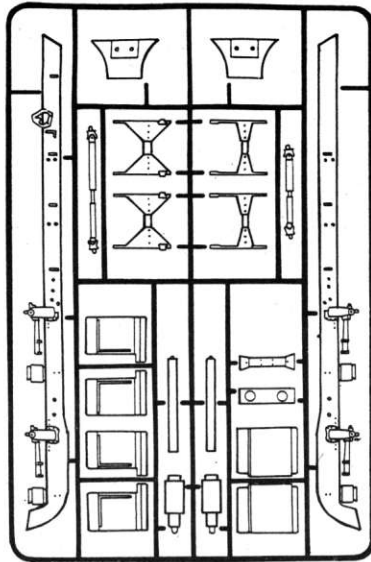

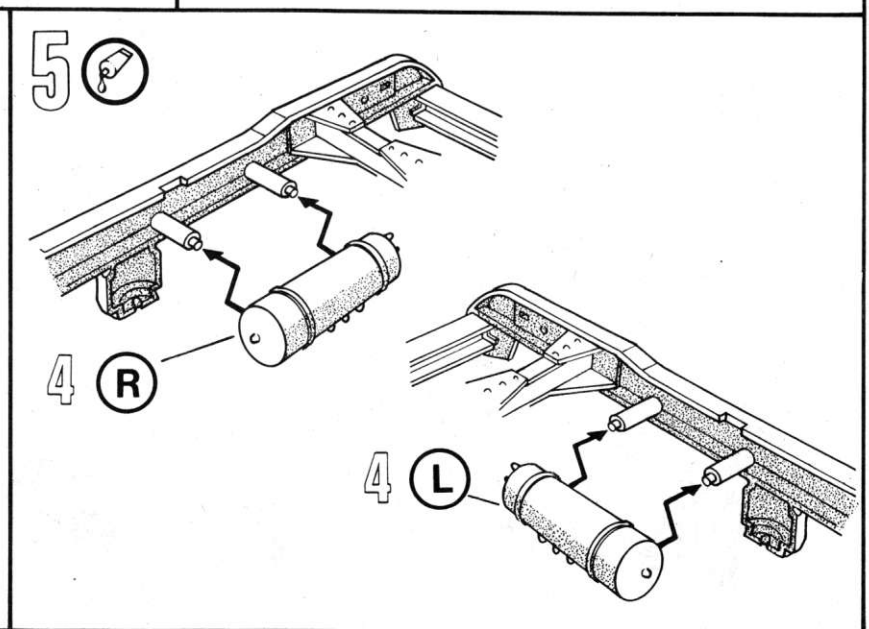
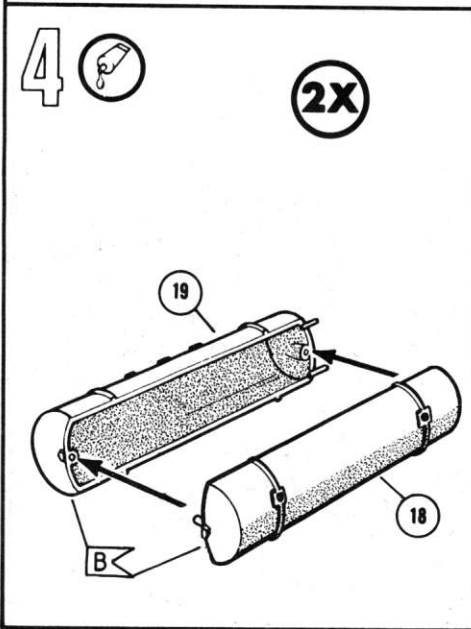
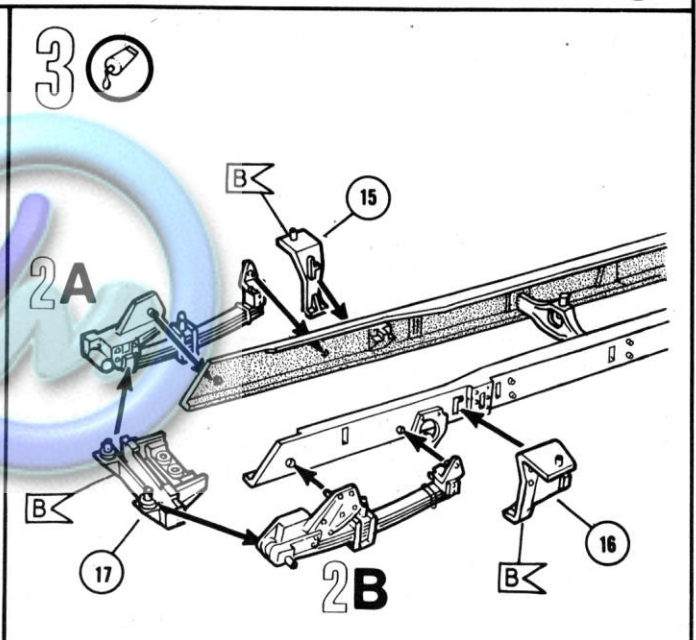
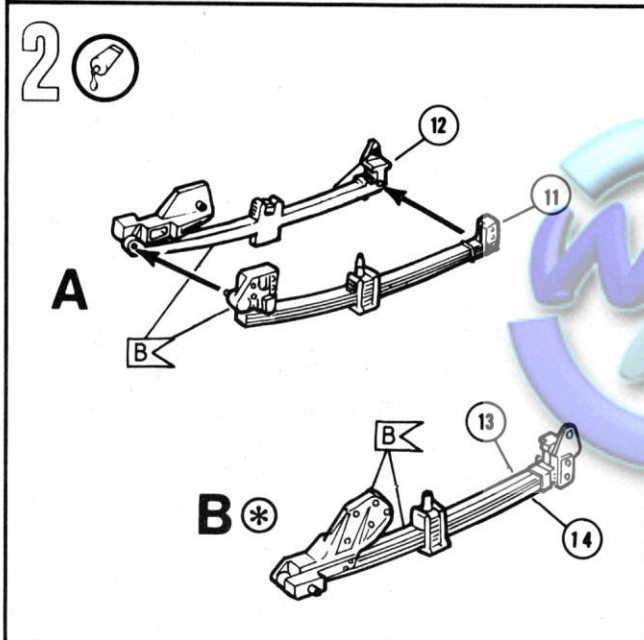
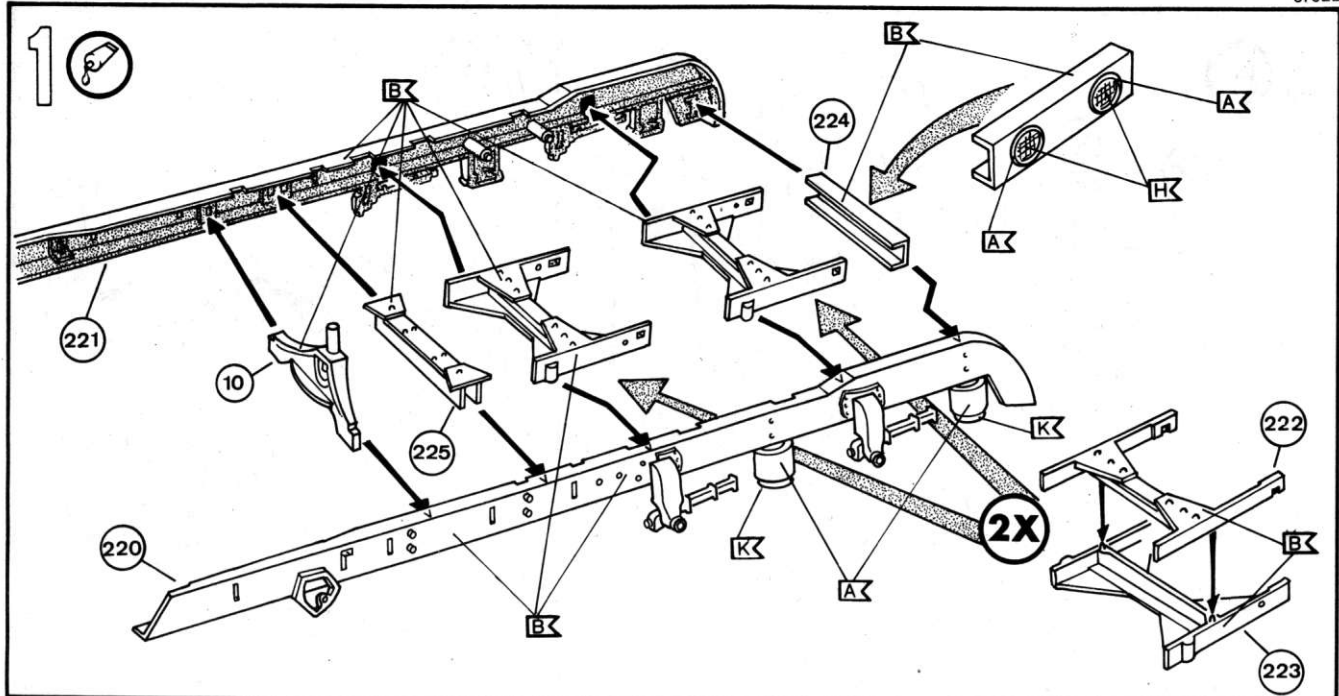

07522

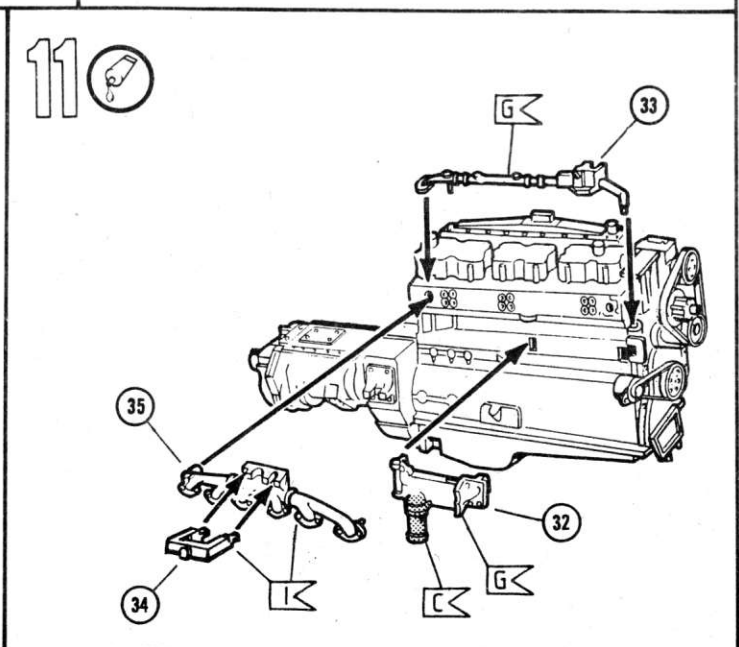
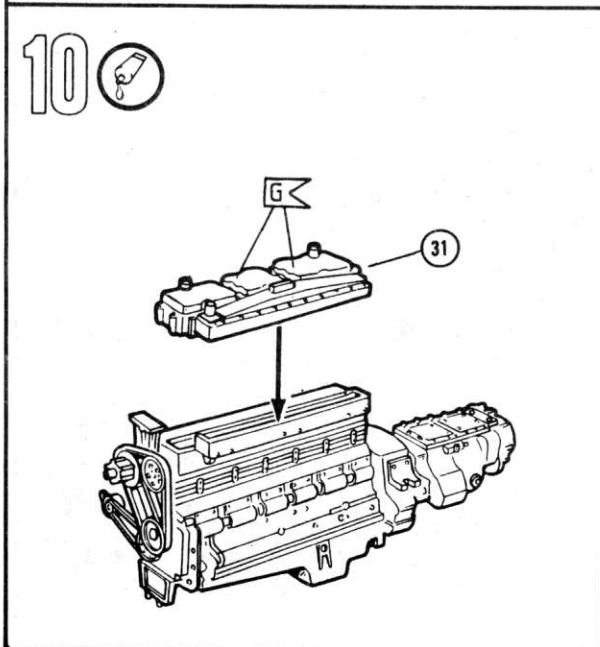
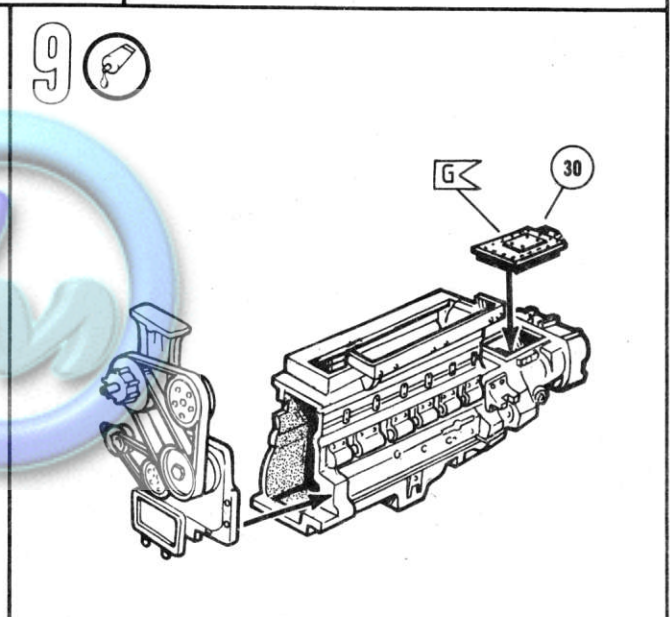
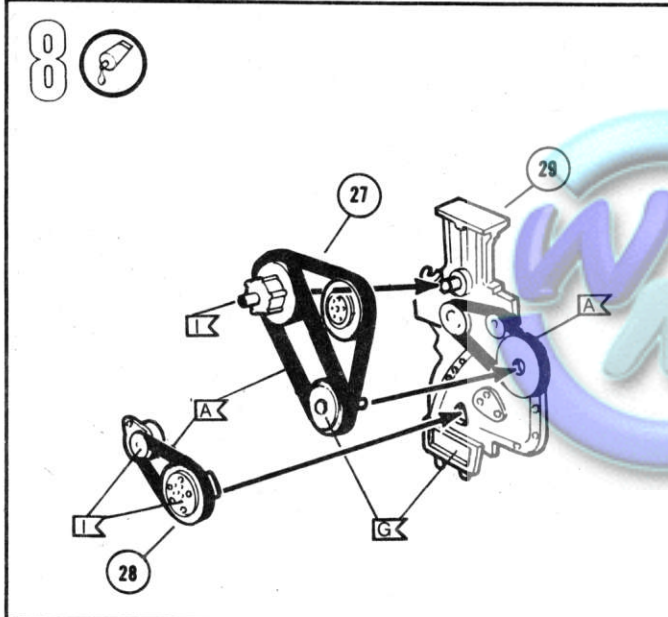
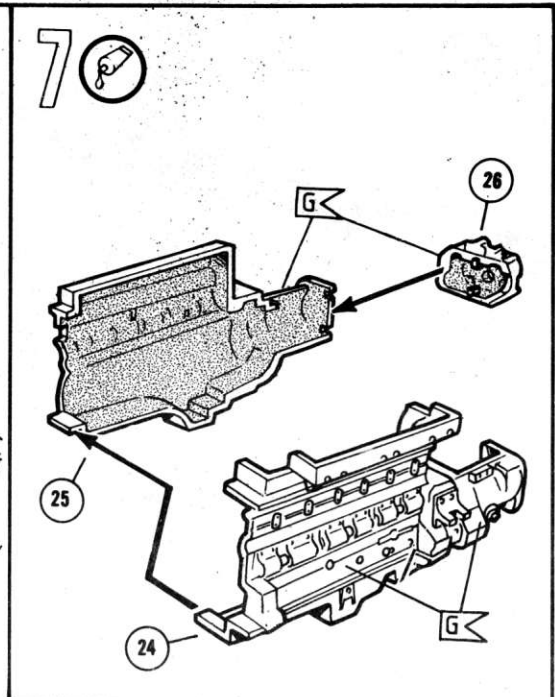
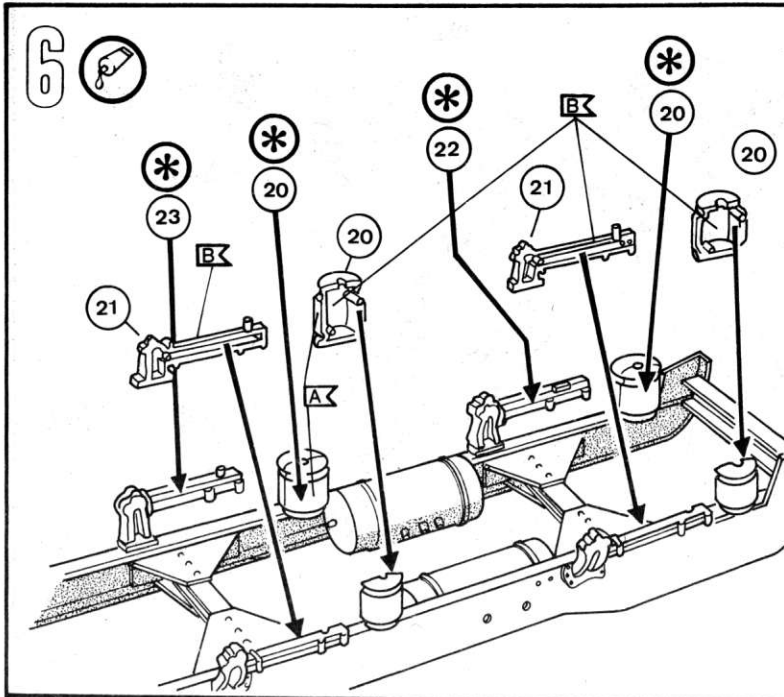

12 

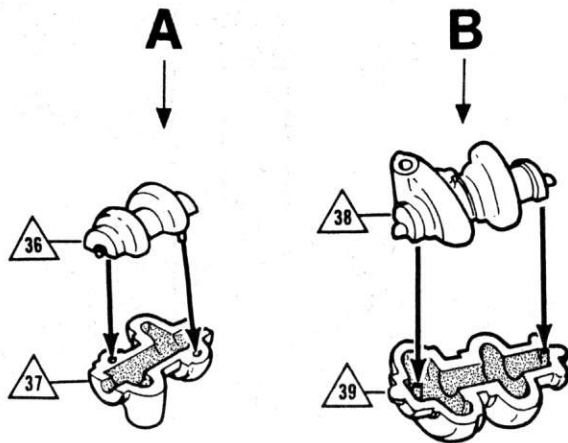

13 

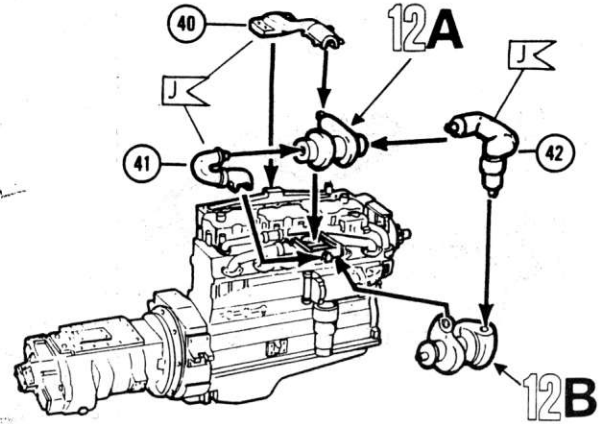

14 

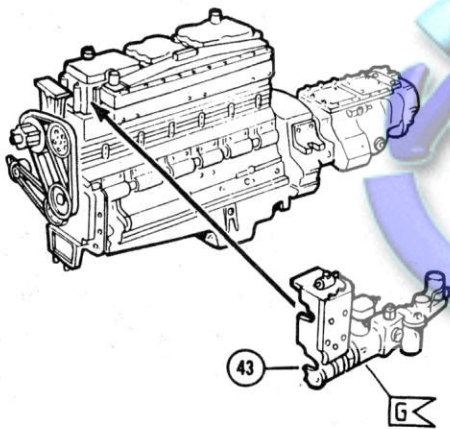

15 

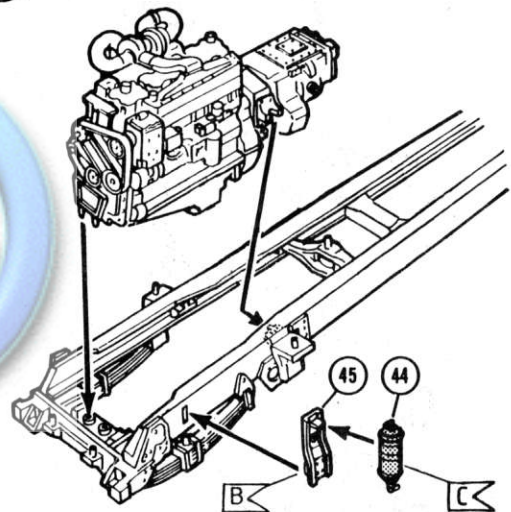

16 

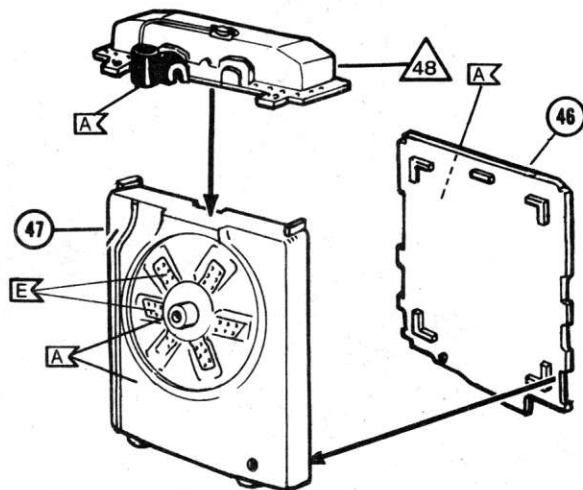

17 

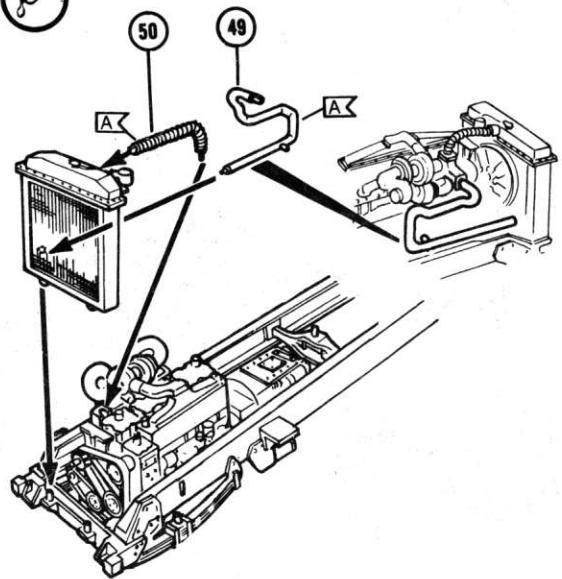

07522

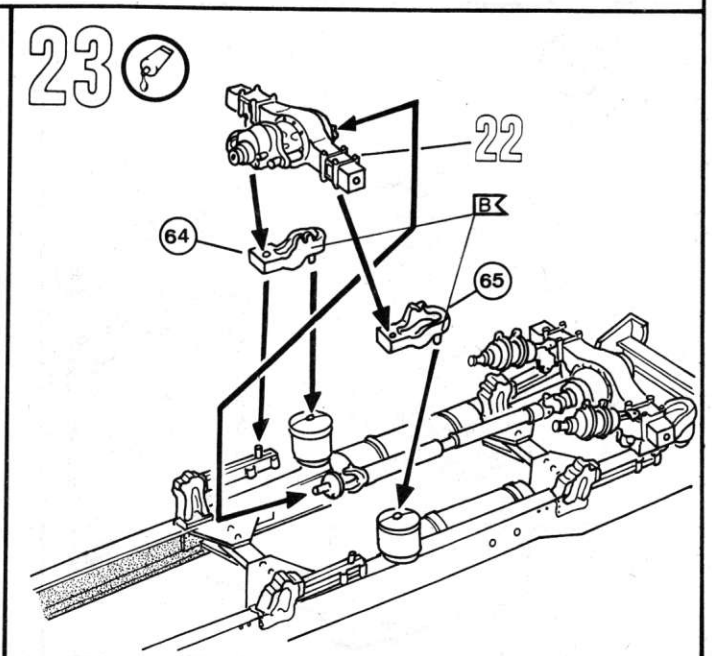
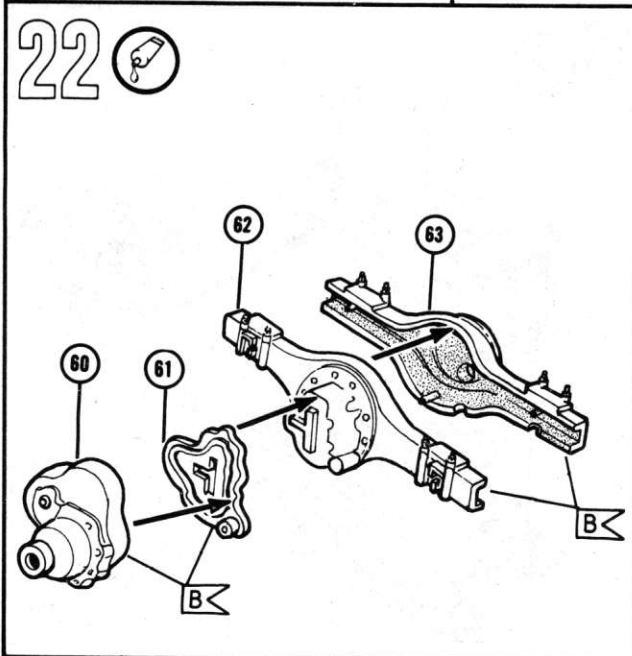
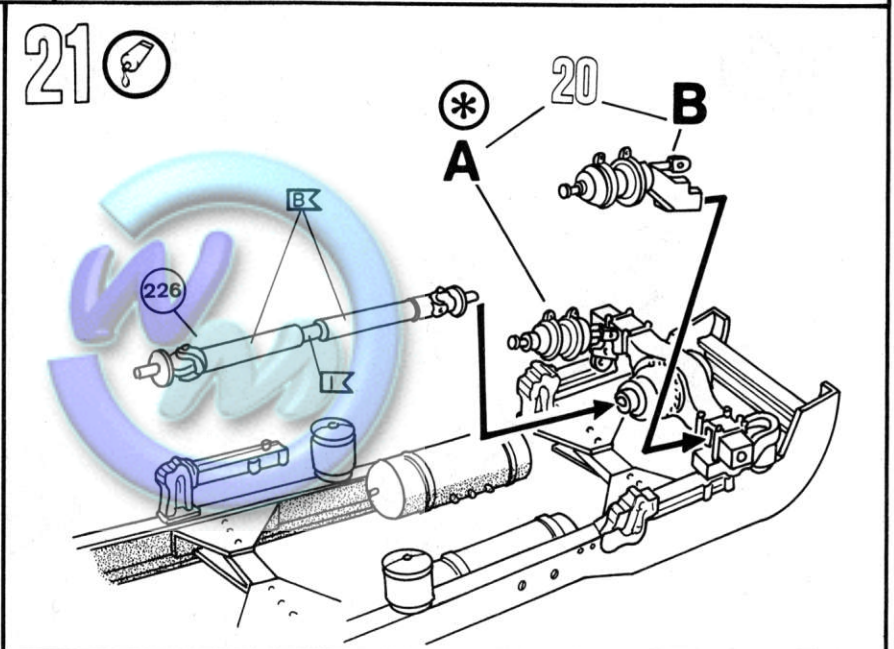
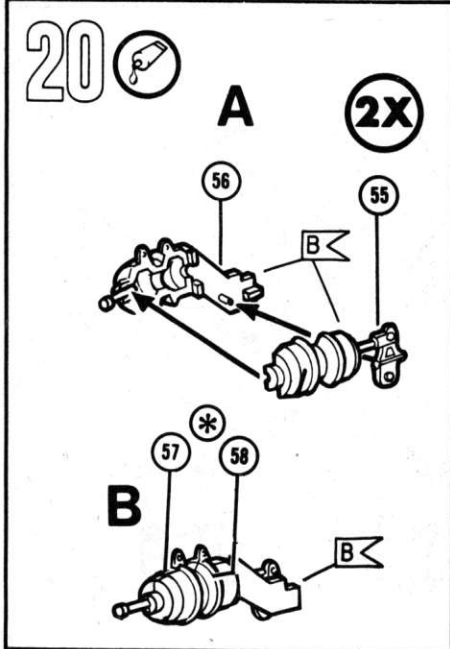
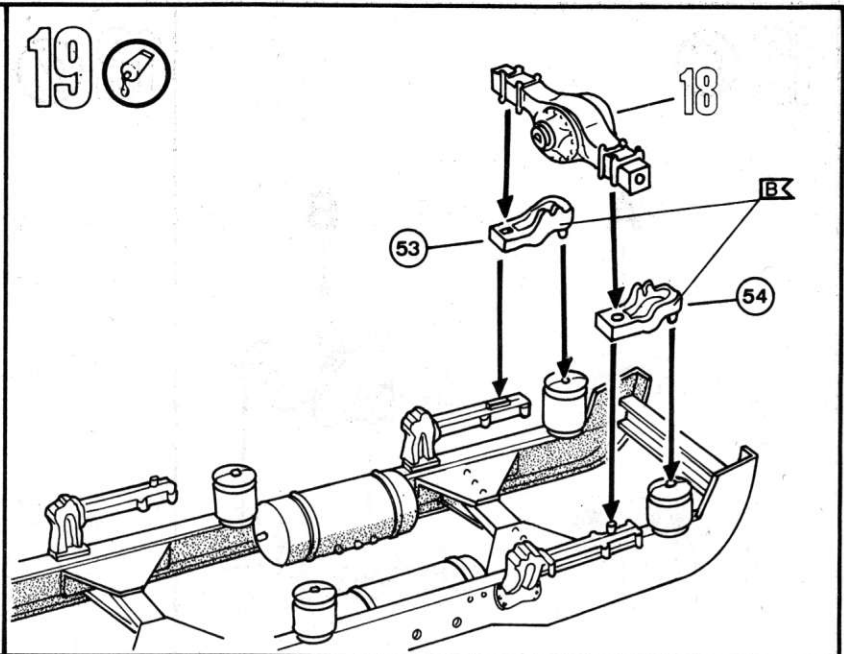
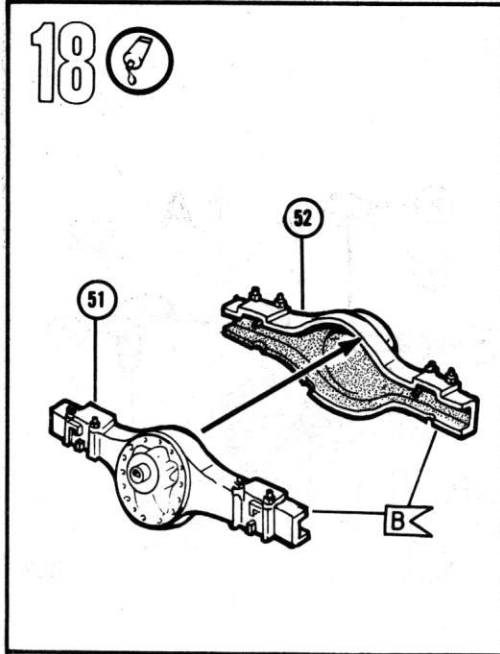

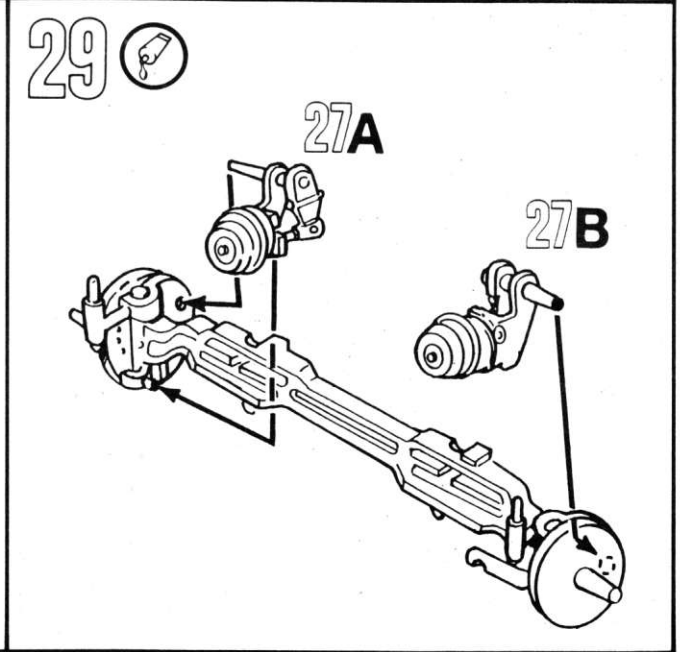
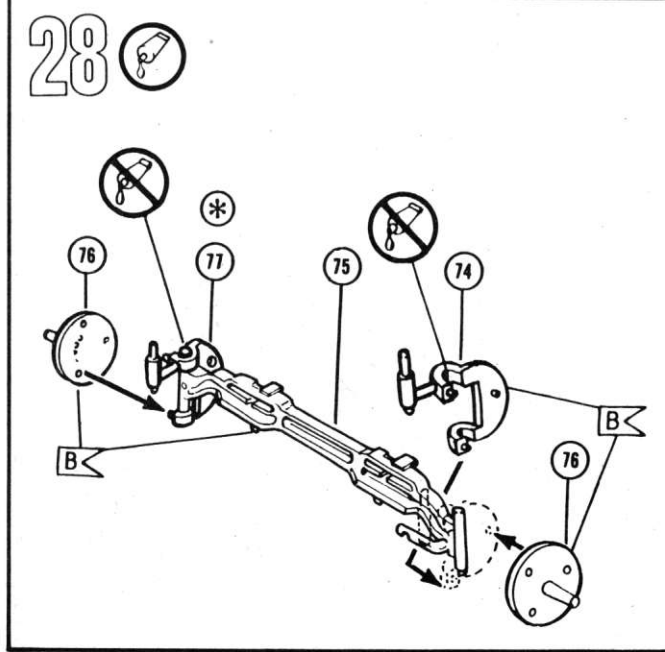
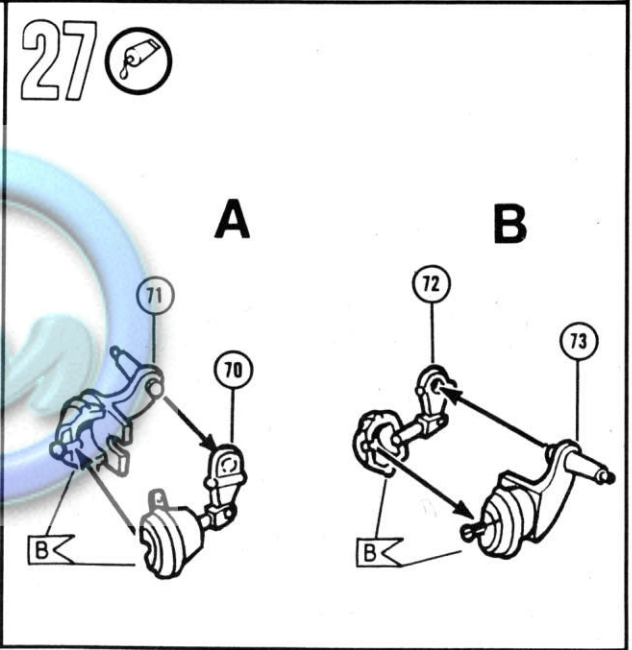
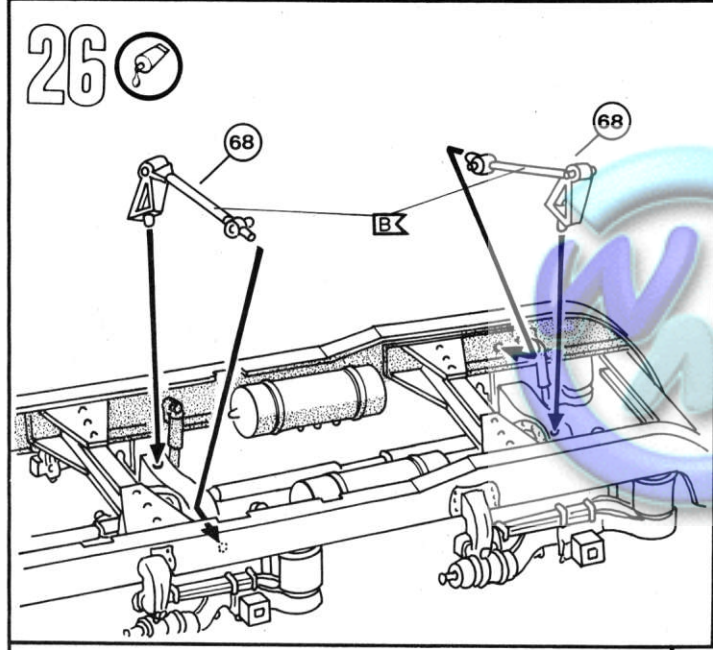
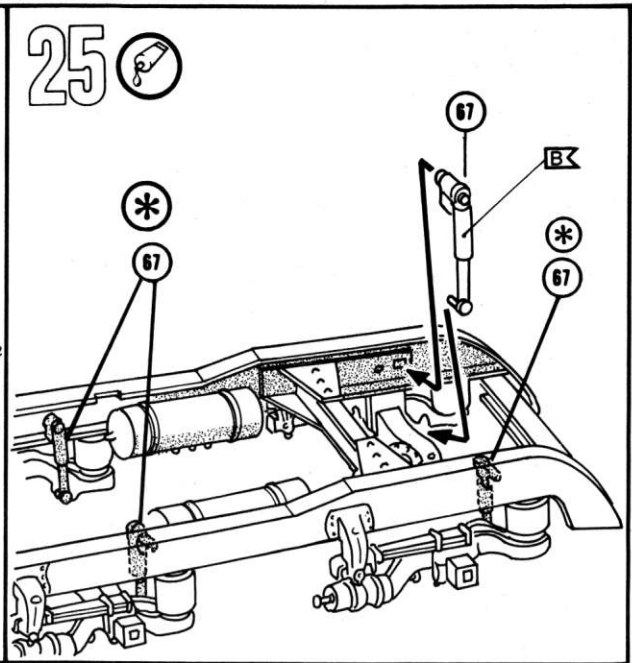
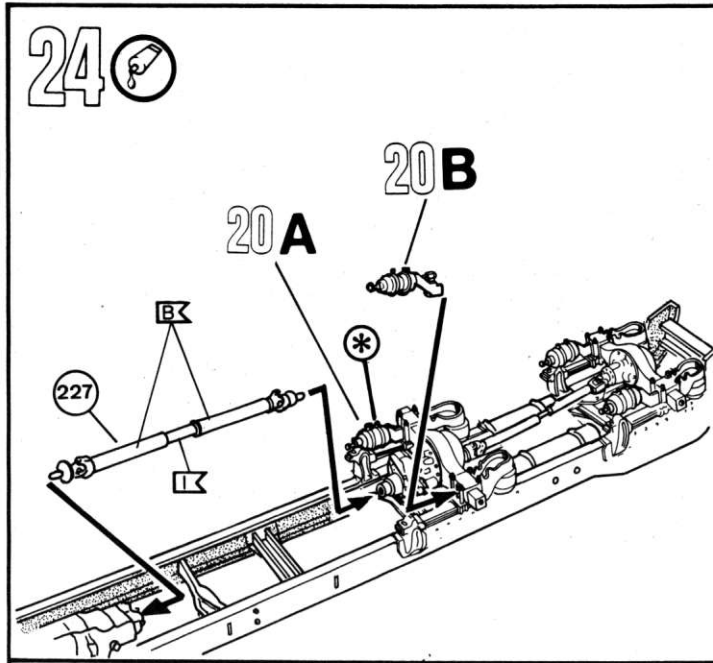

07522

30

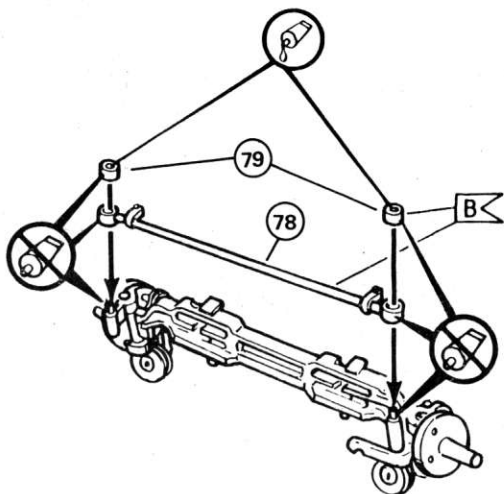

31

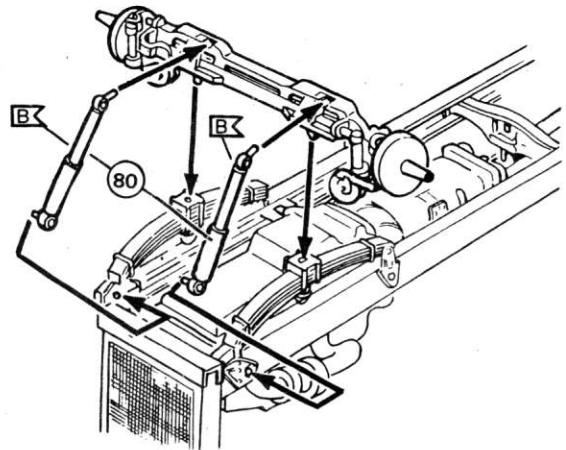

32

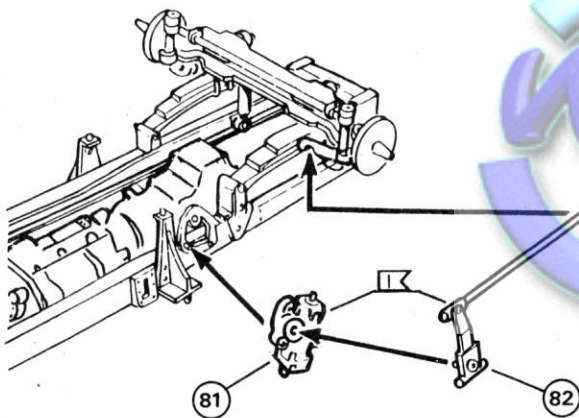

33

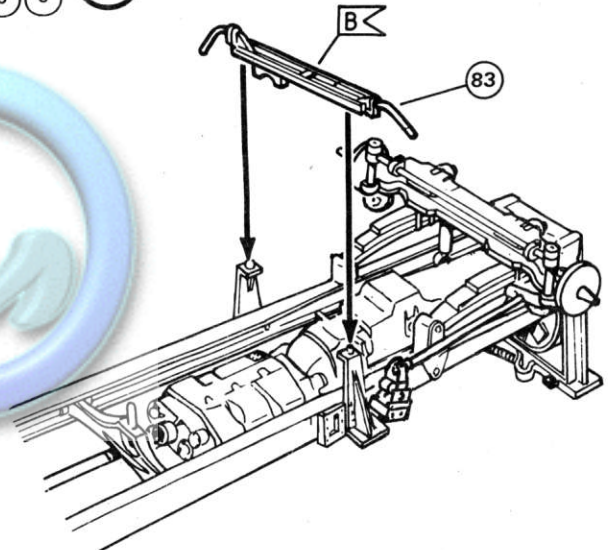

34

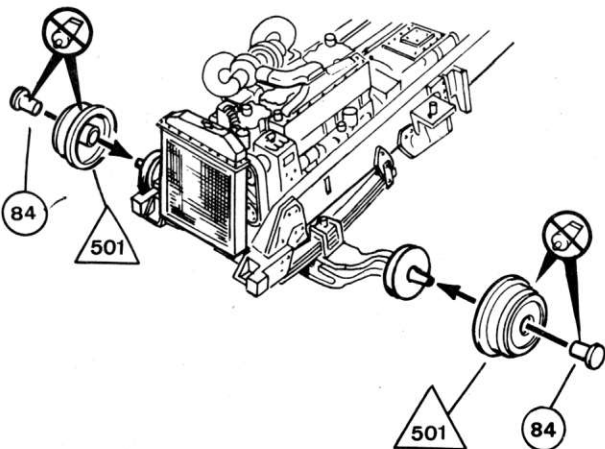

35

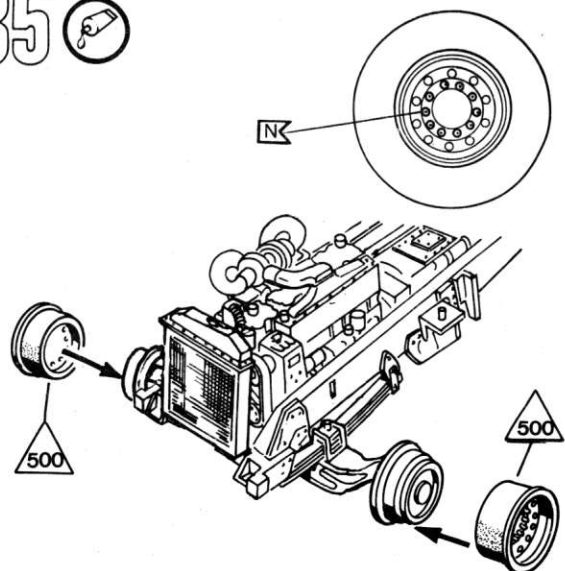

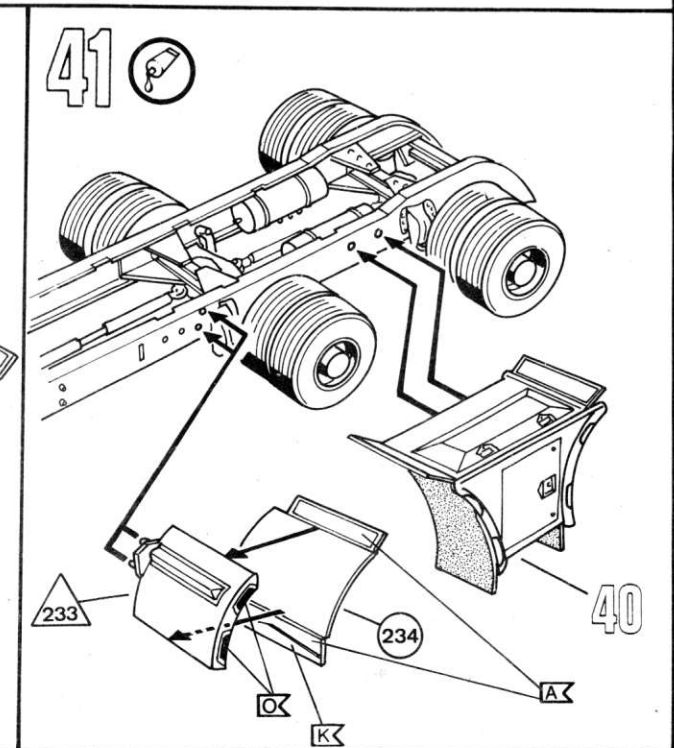
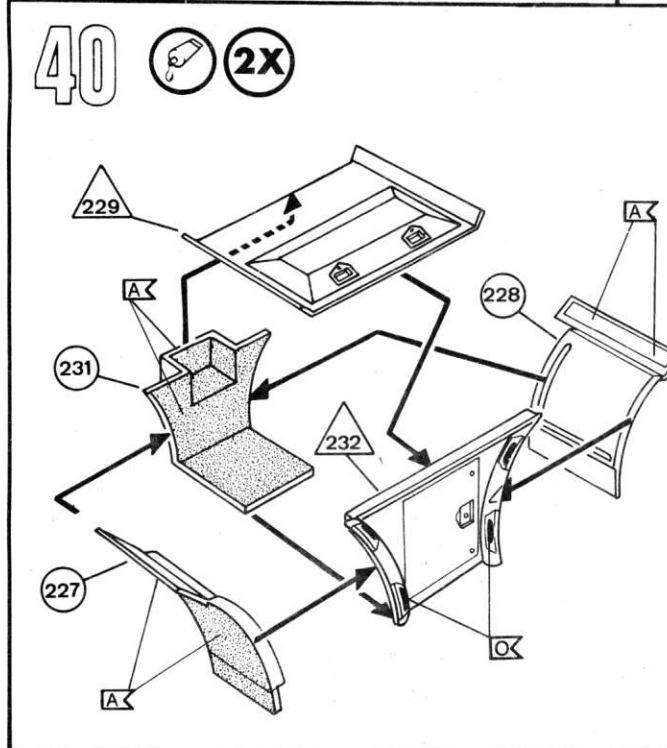
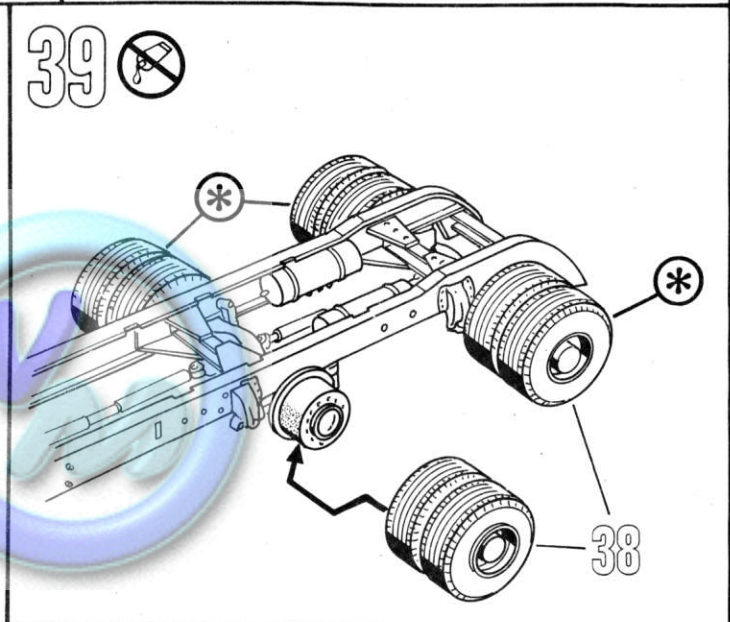
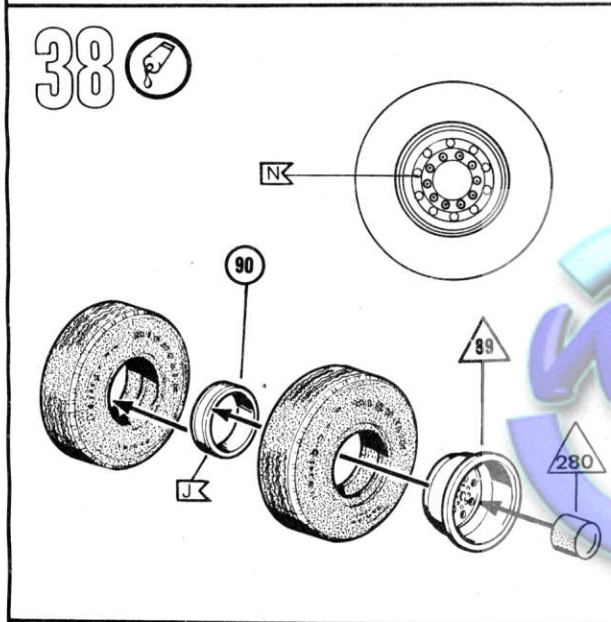
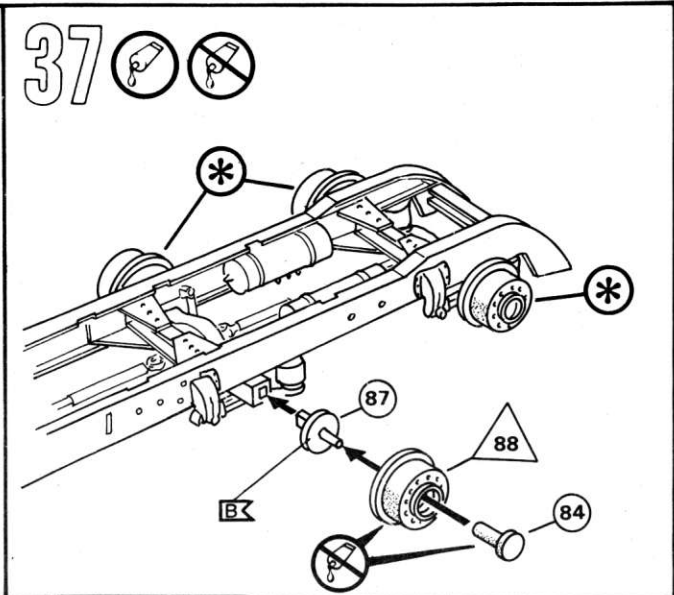
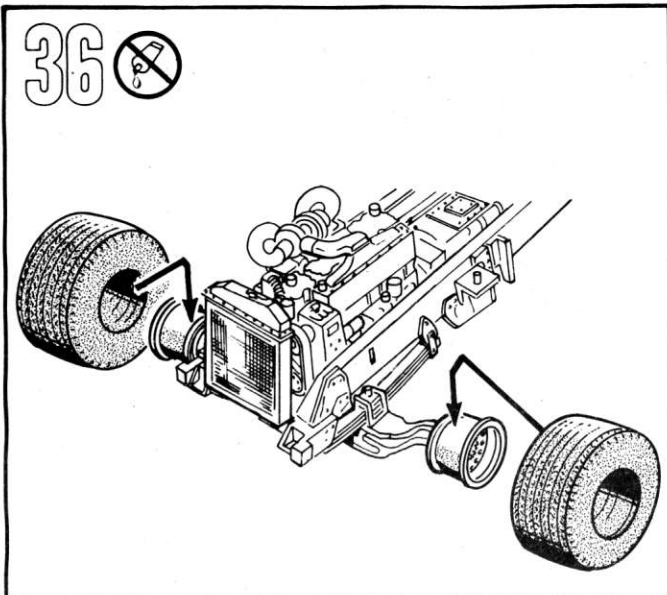

07522

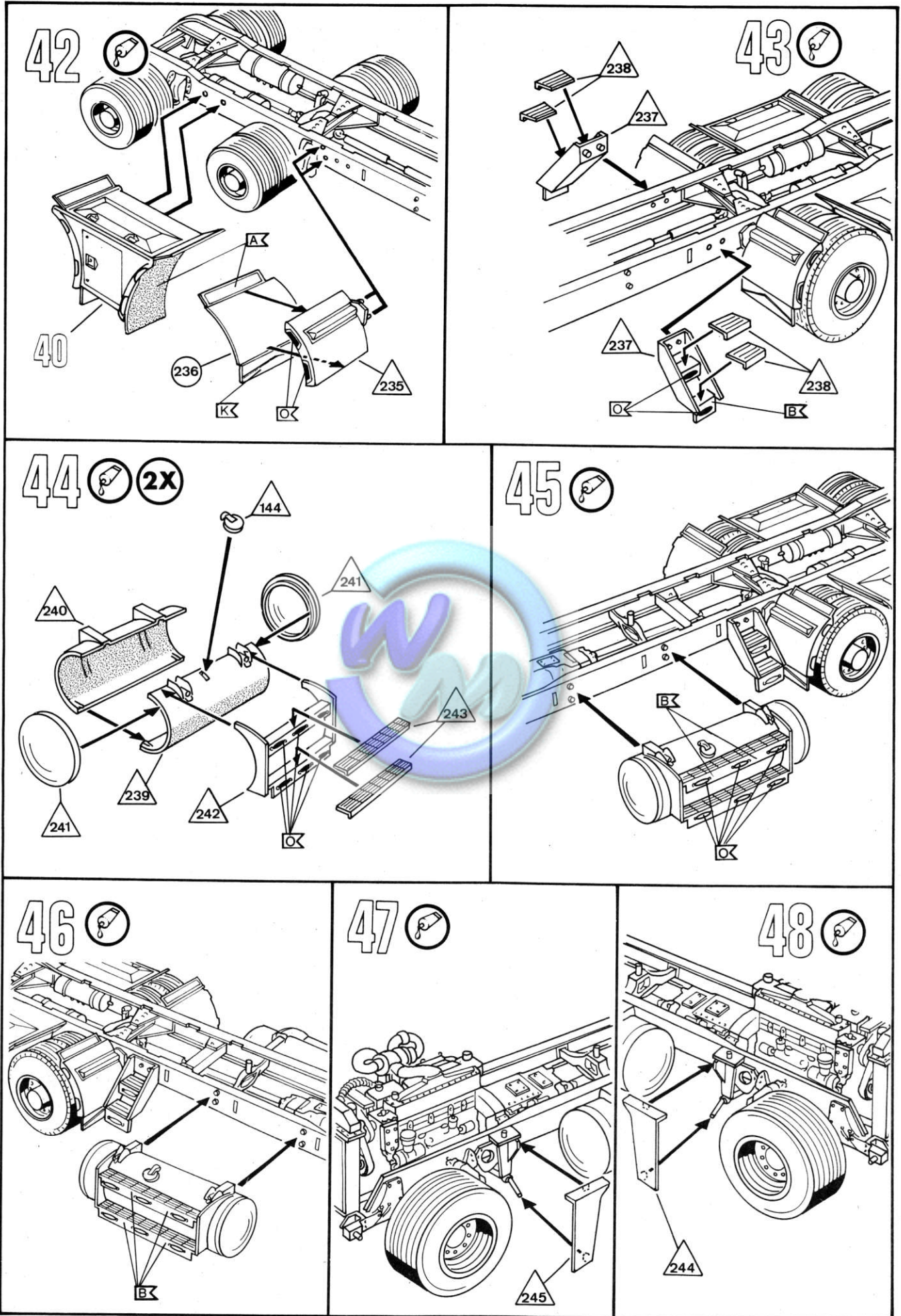

49 

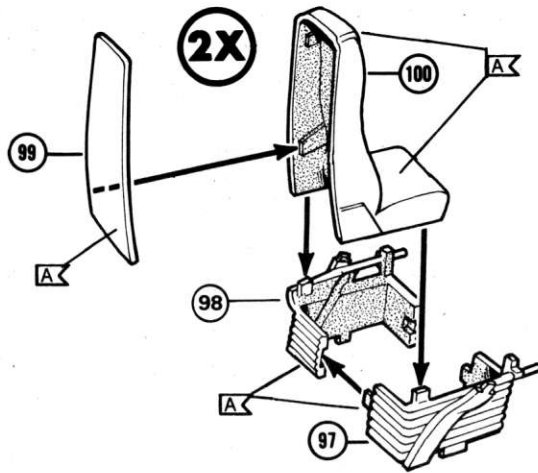

50 

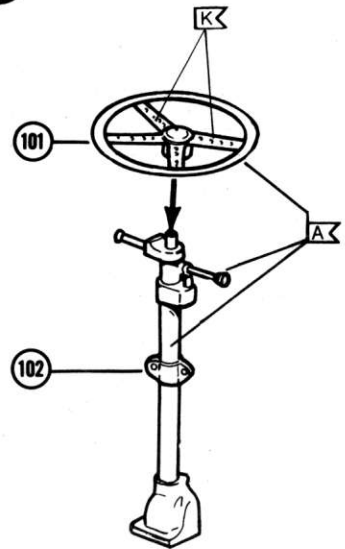

51 

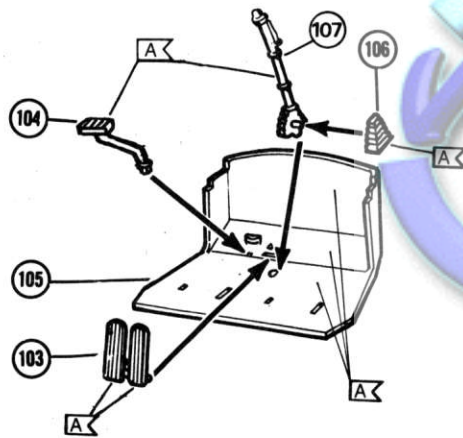

52 

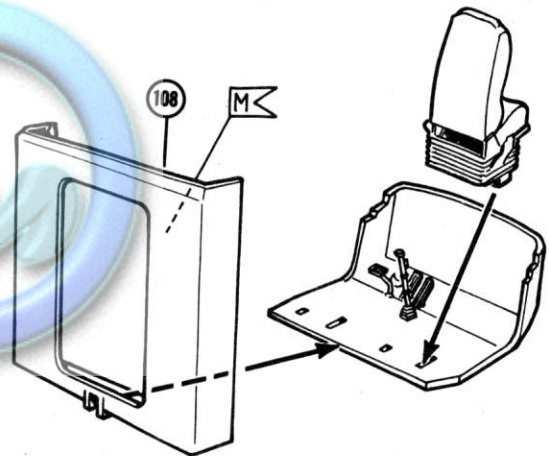

53 

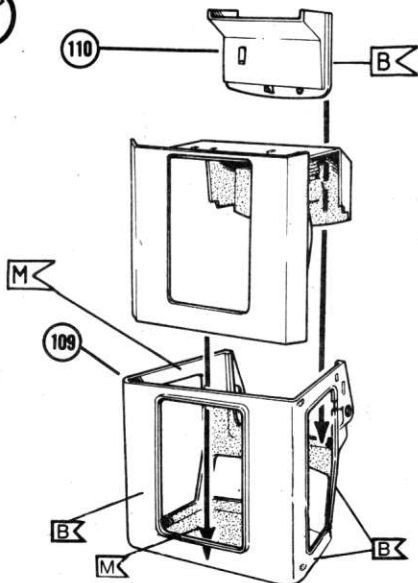

54 

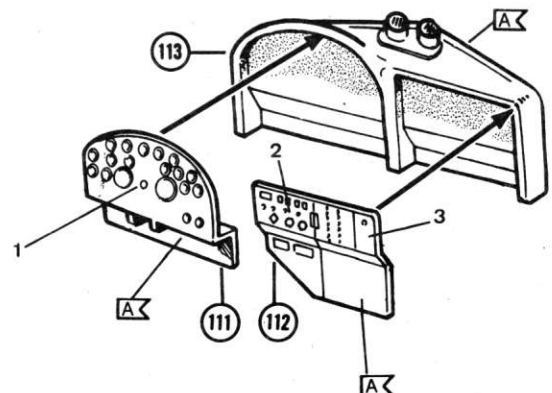

07522

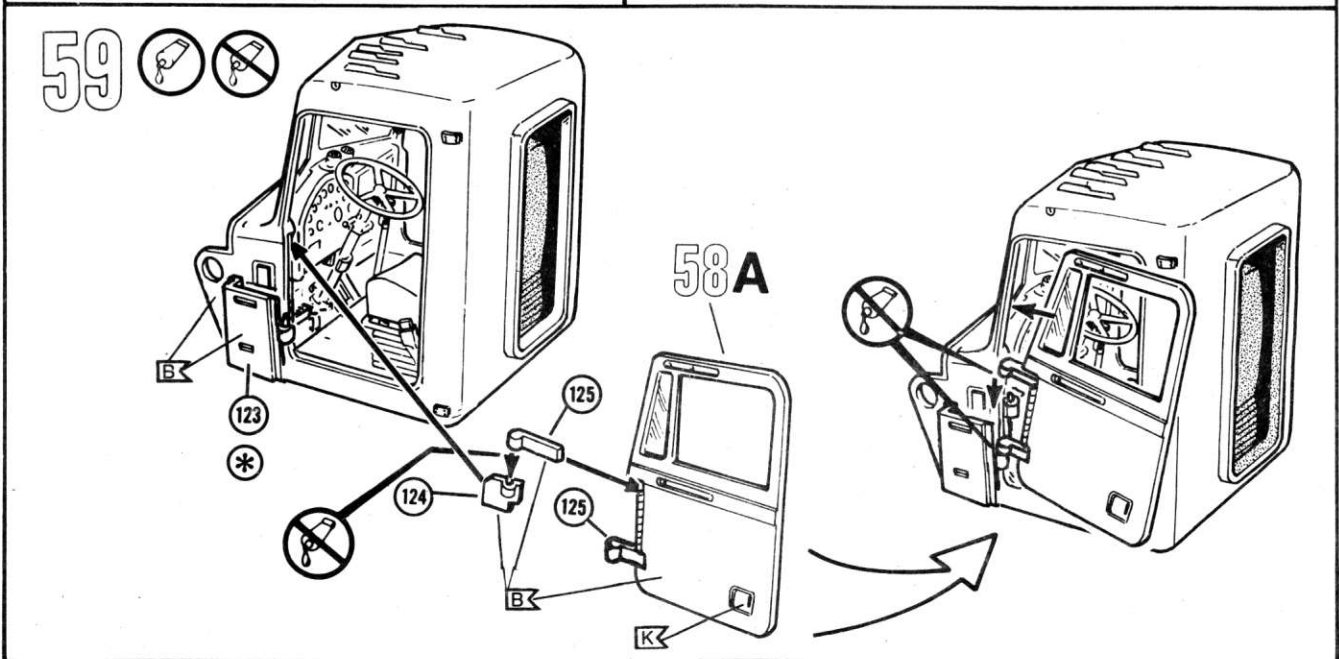
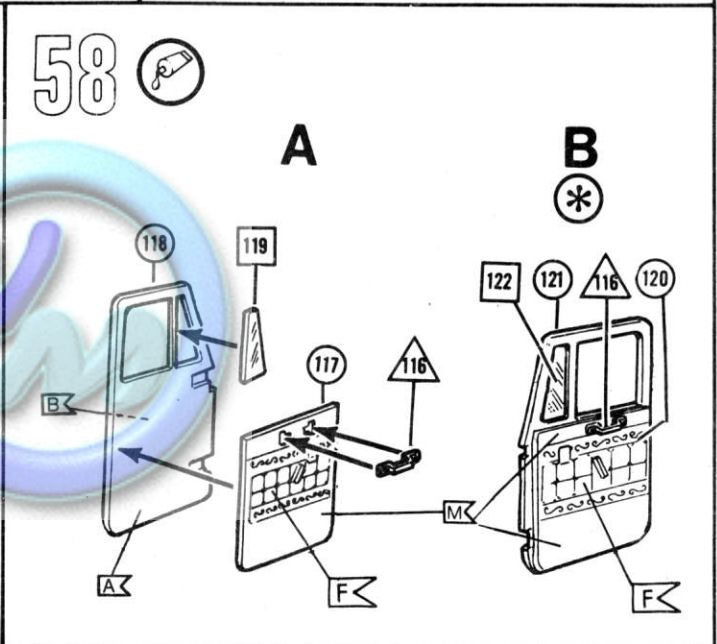
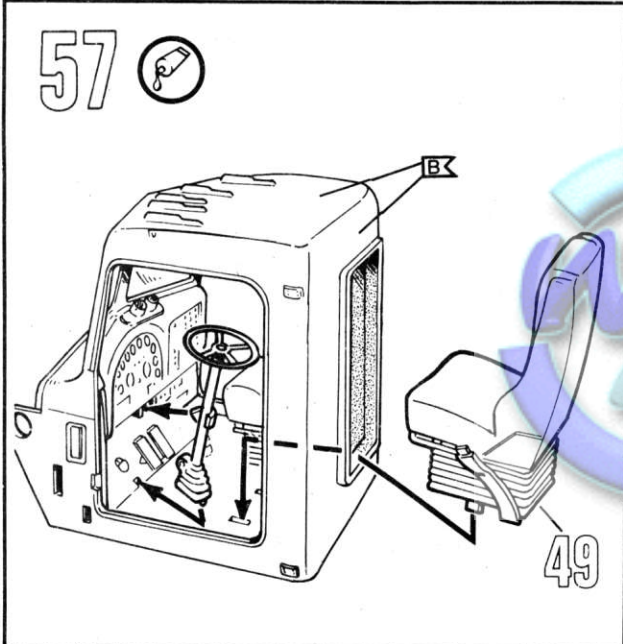
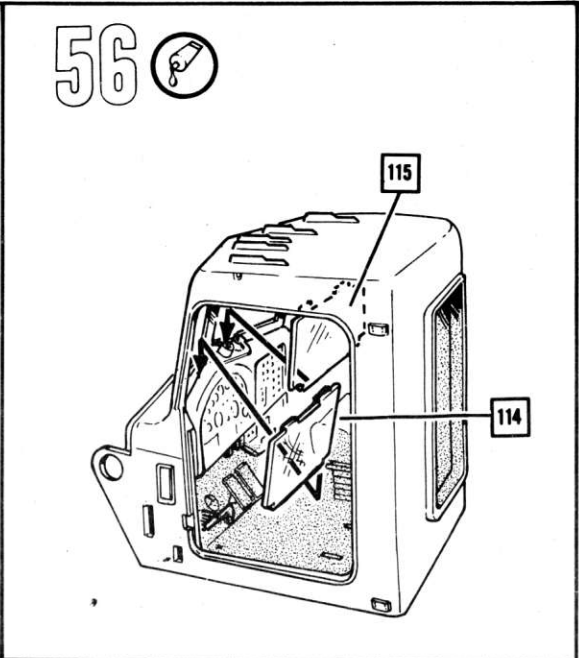
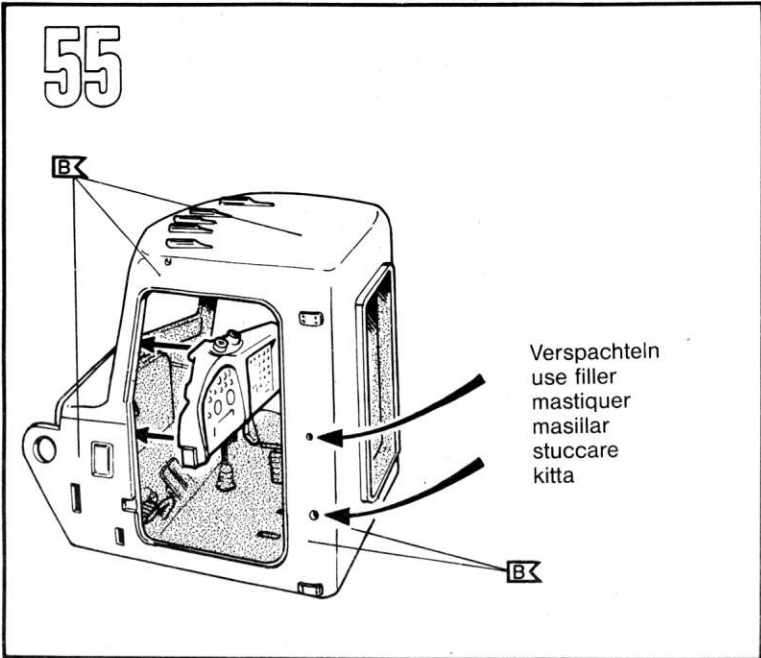

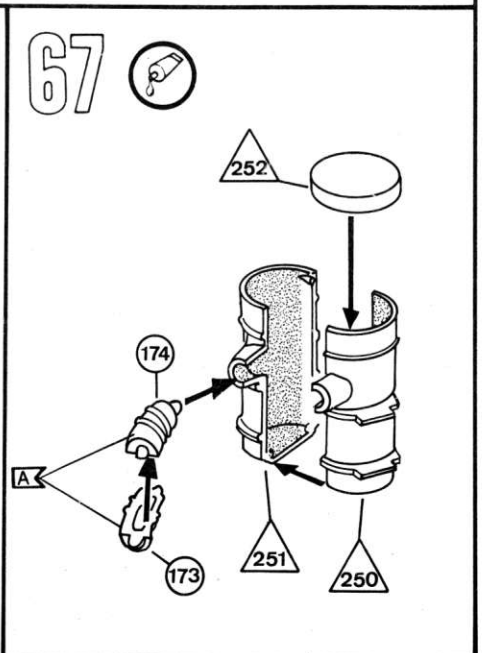
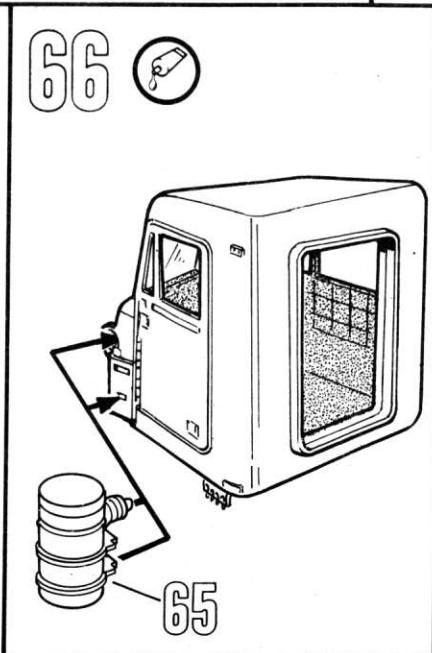
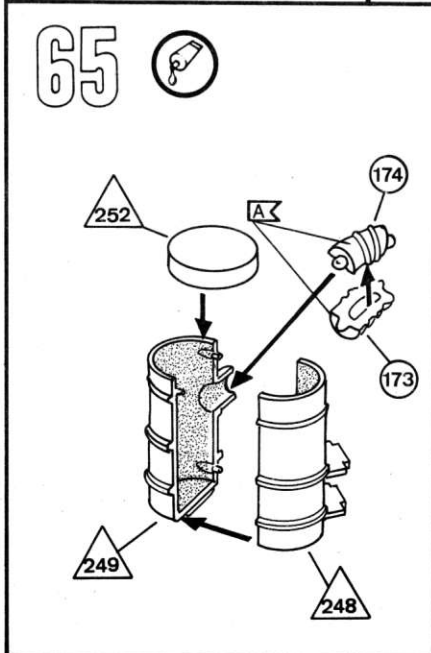
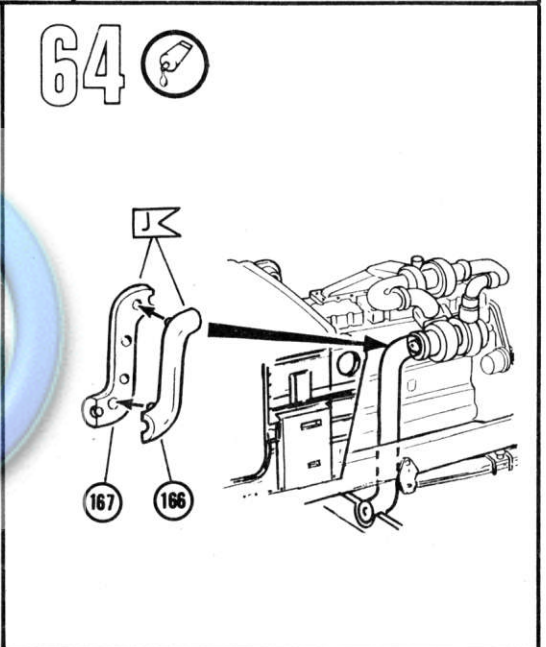
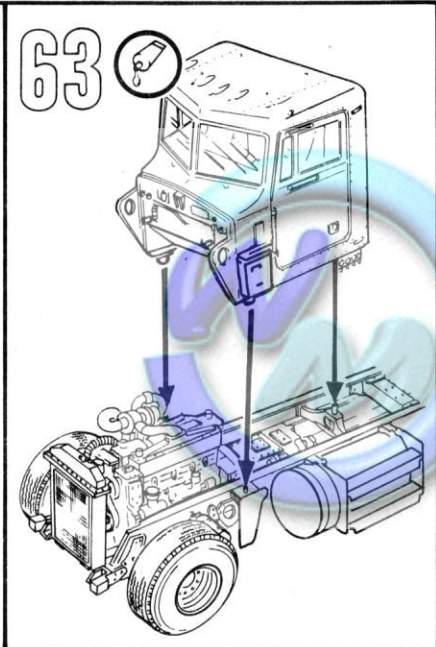
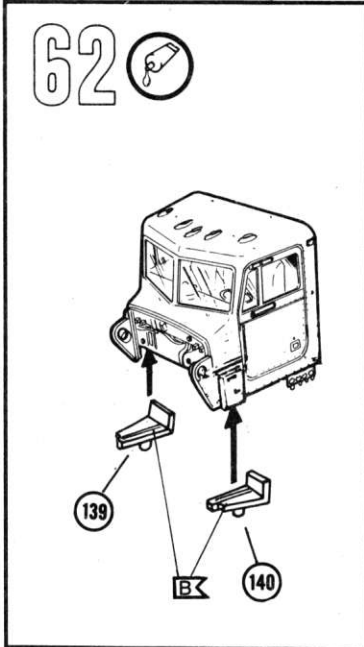
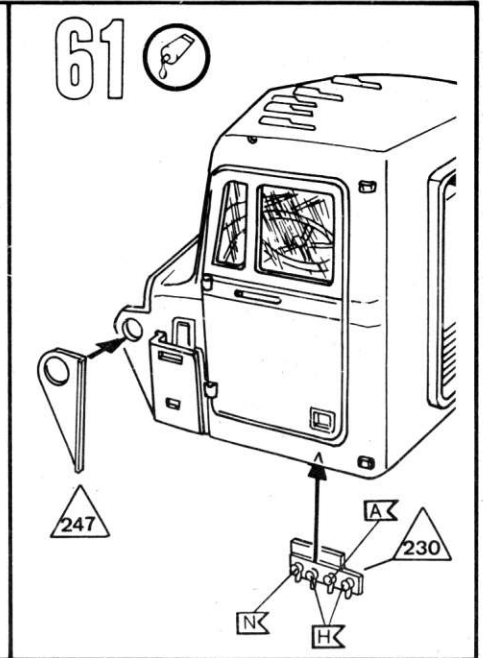
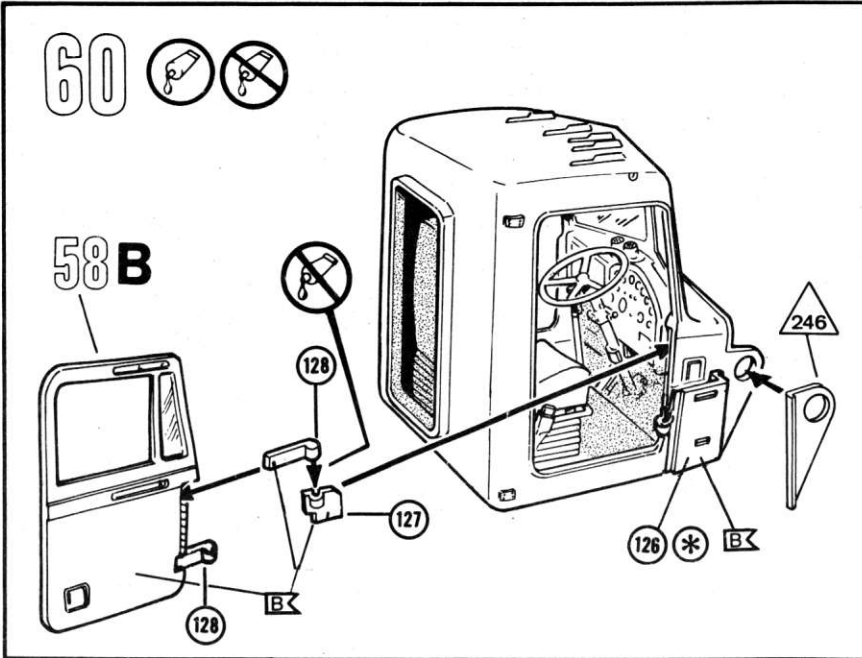

07522

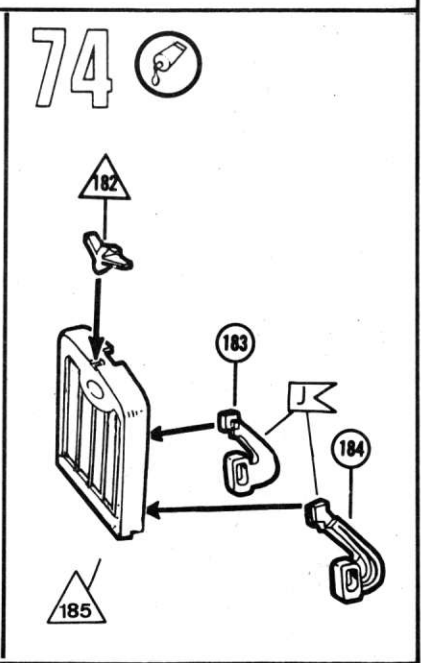
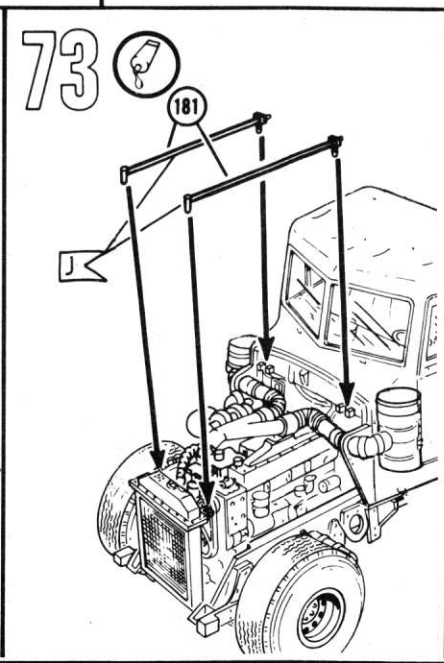
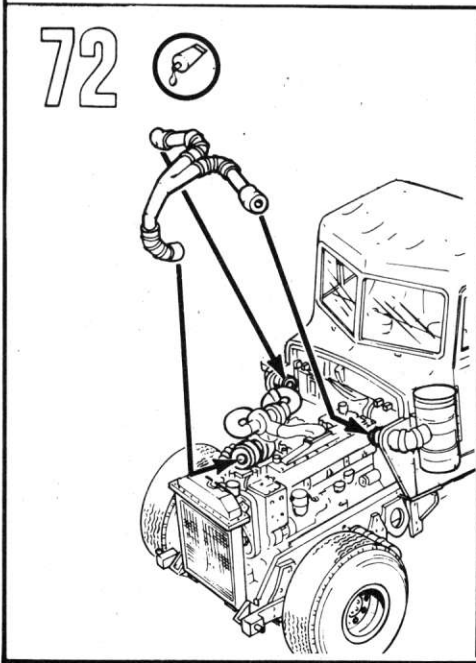
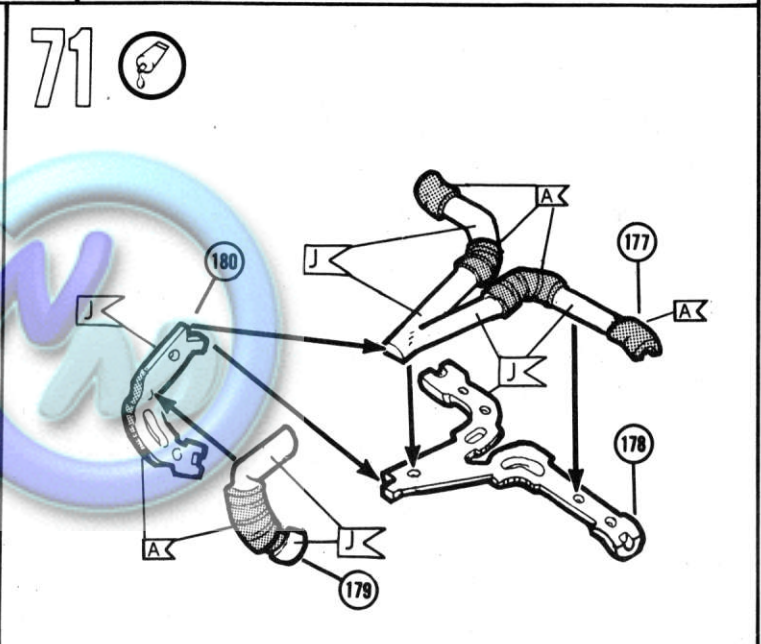
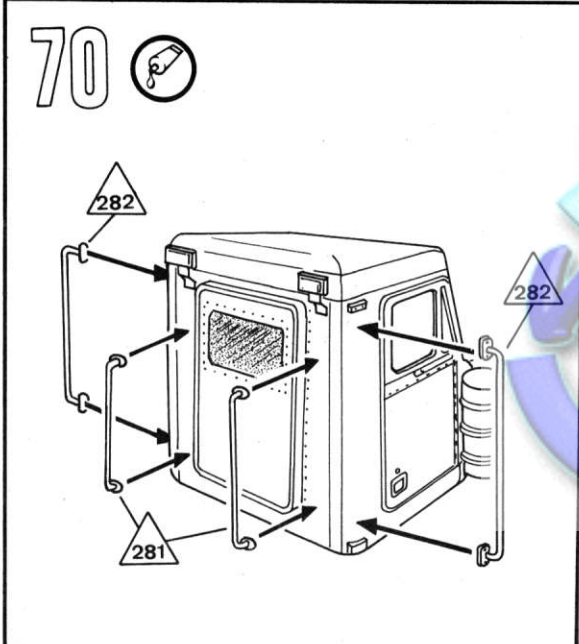
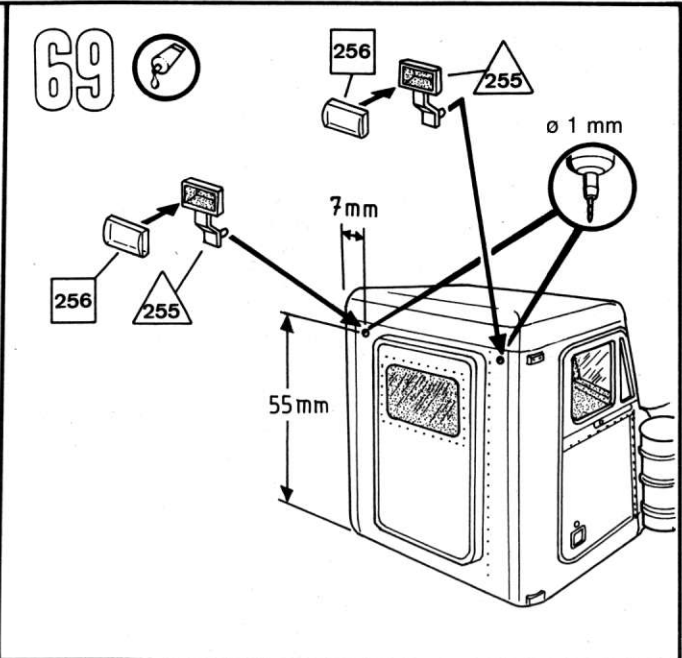
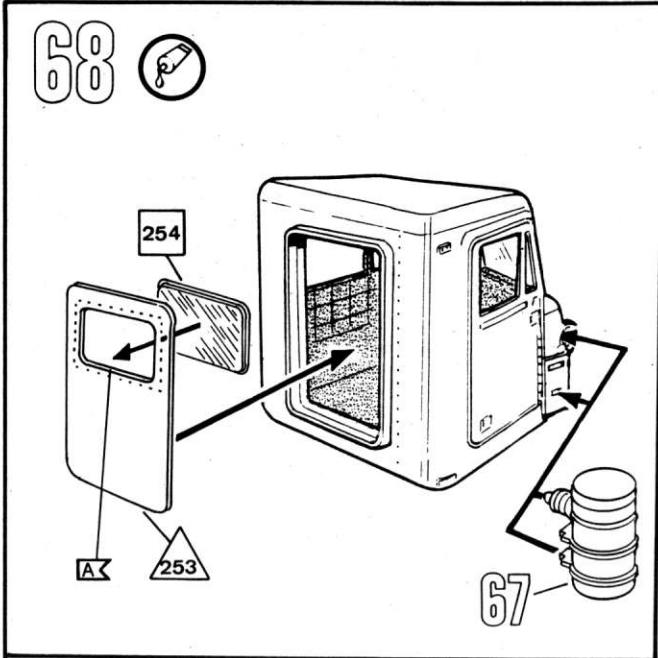

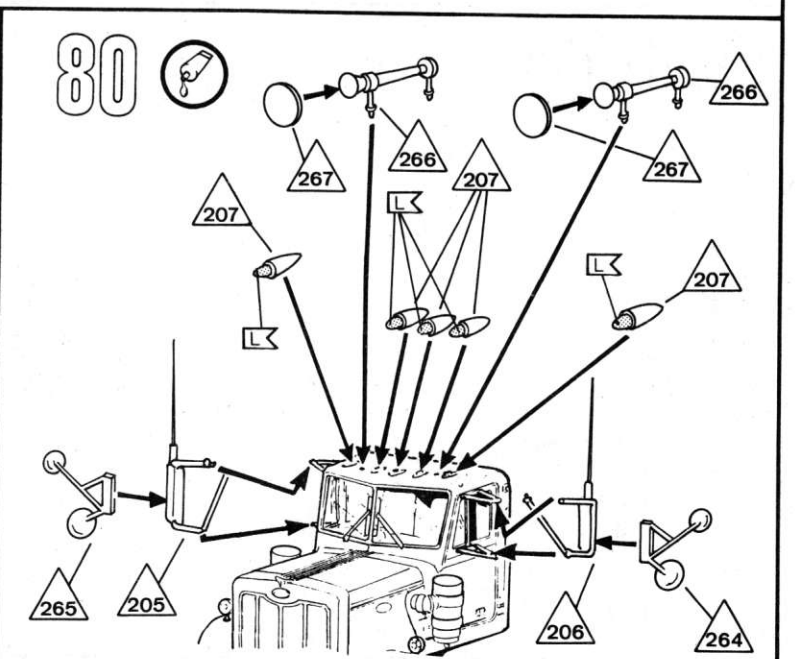
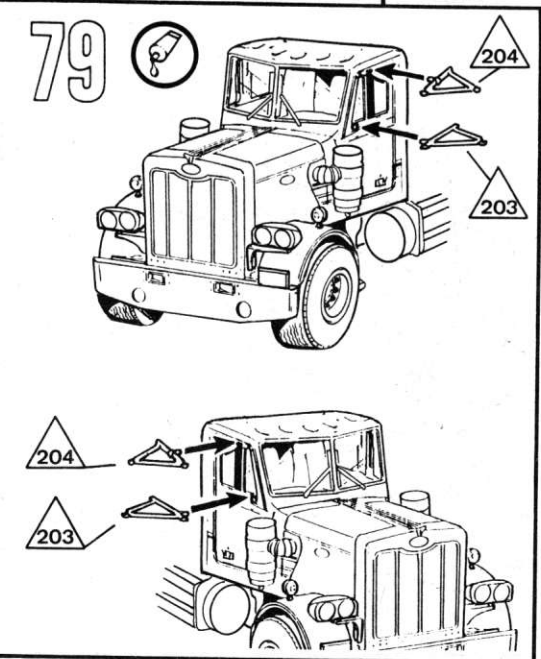
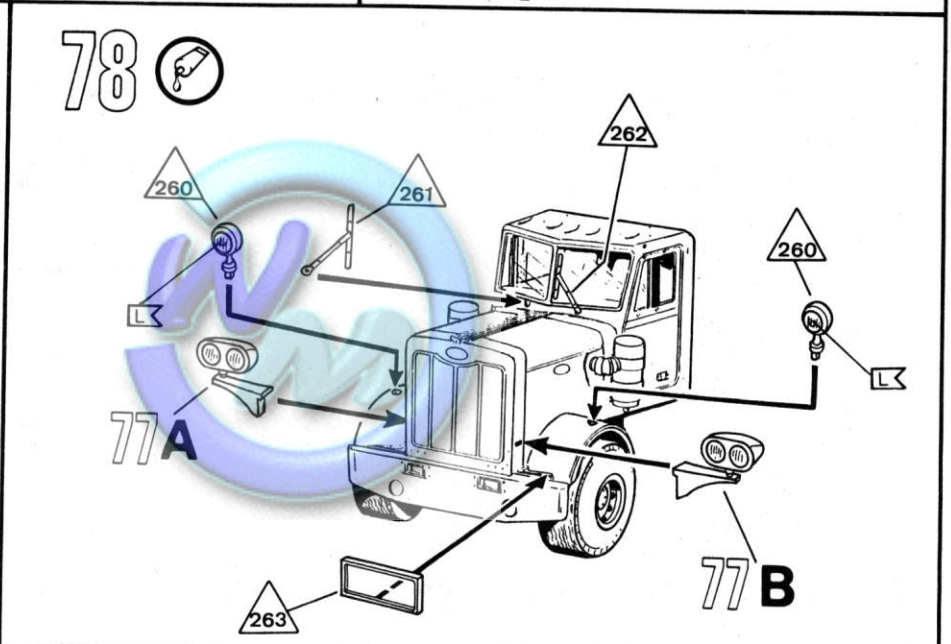
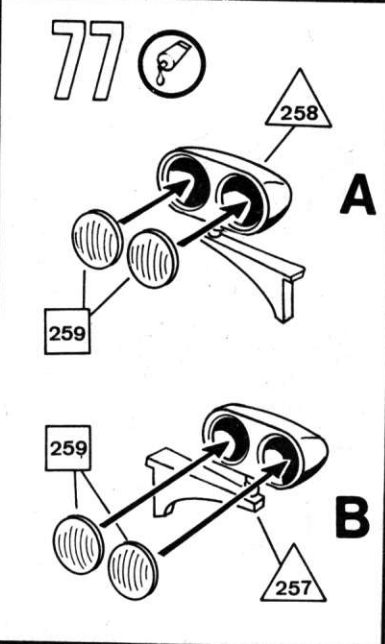
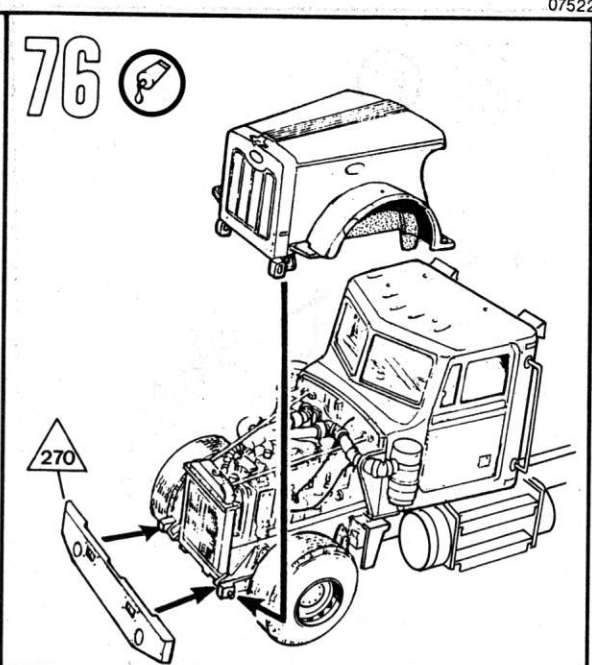
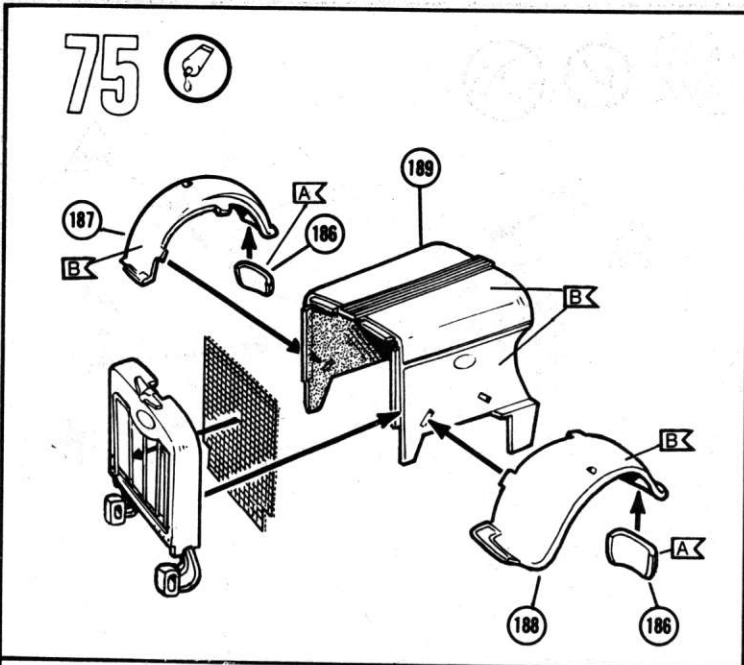

07522

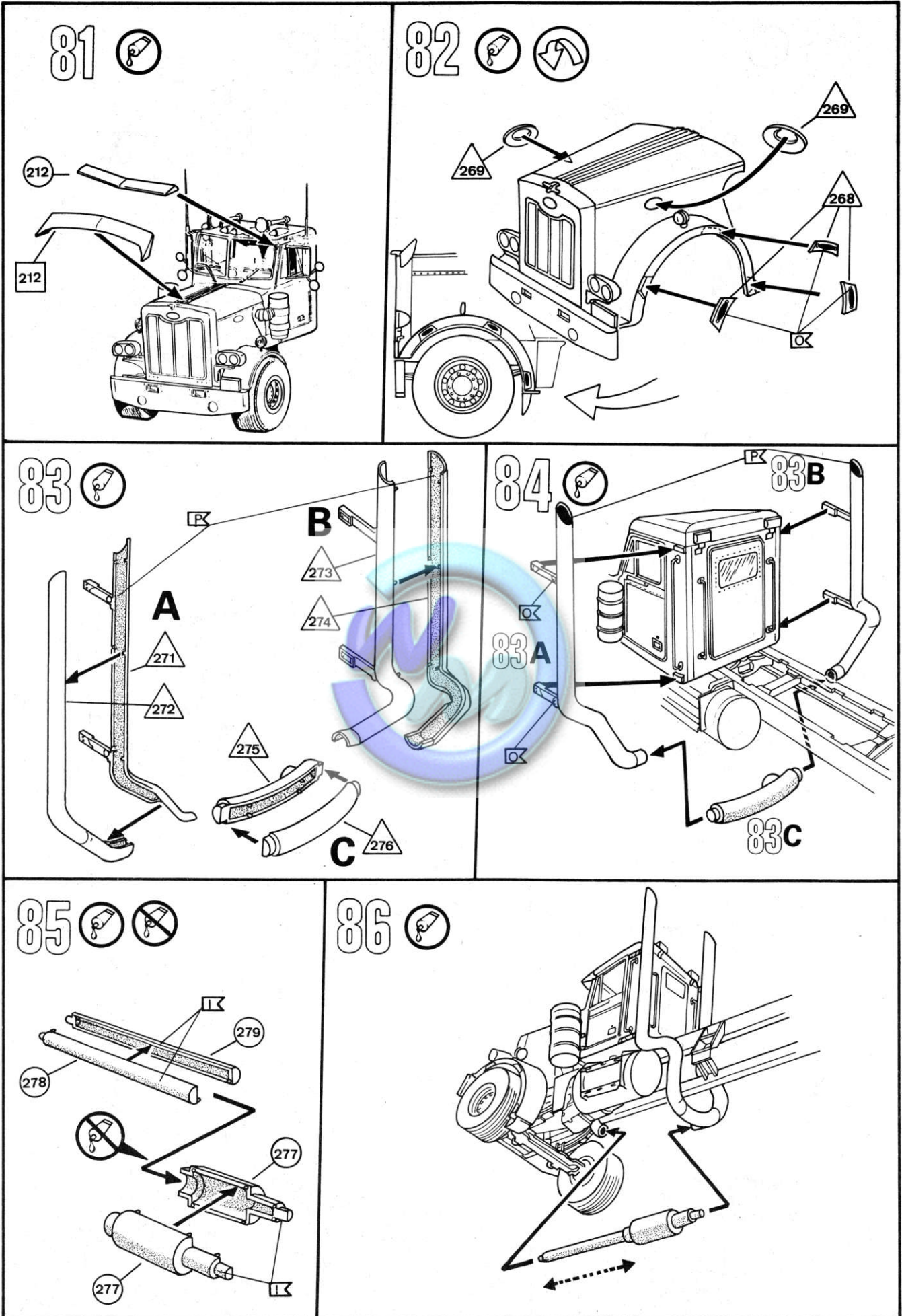

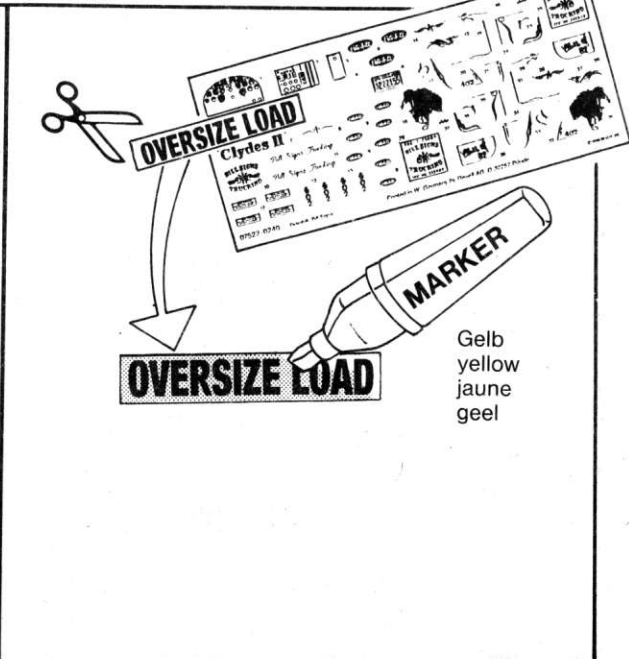
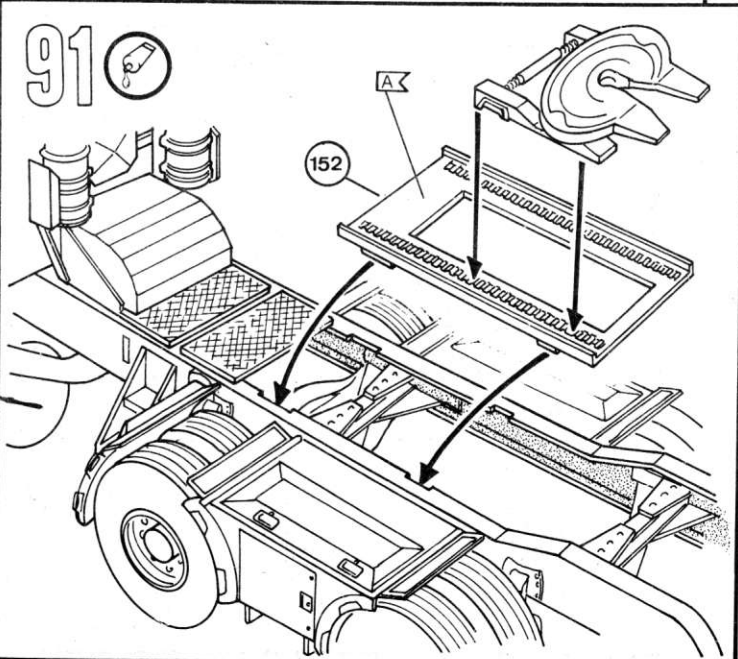
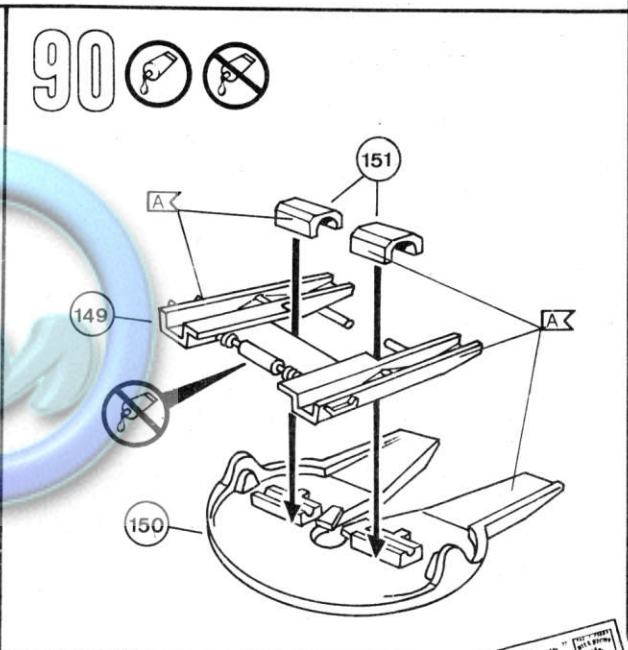
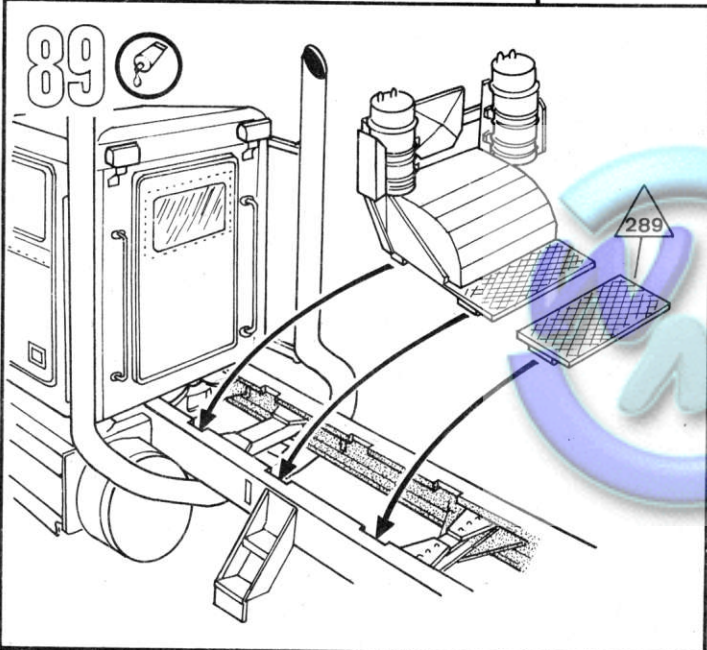
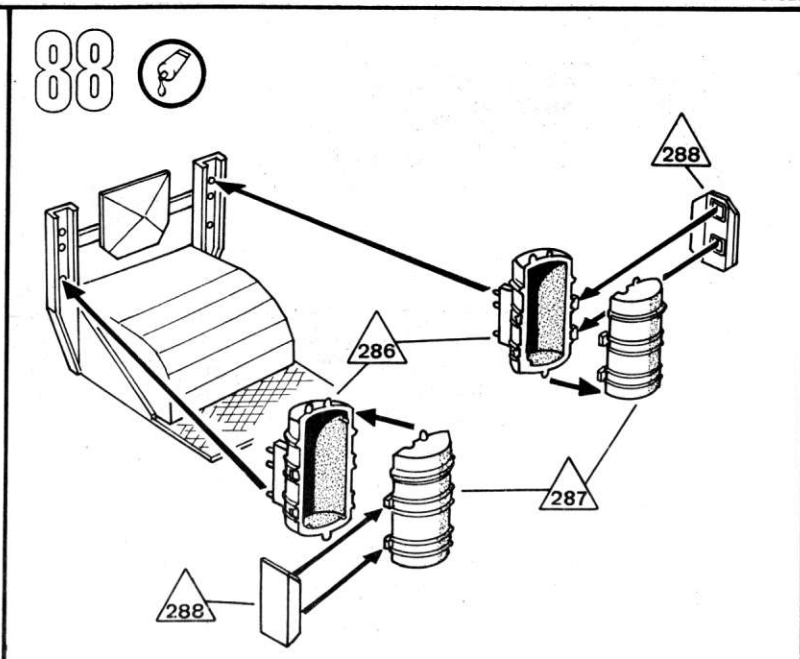
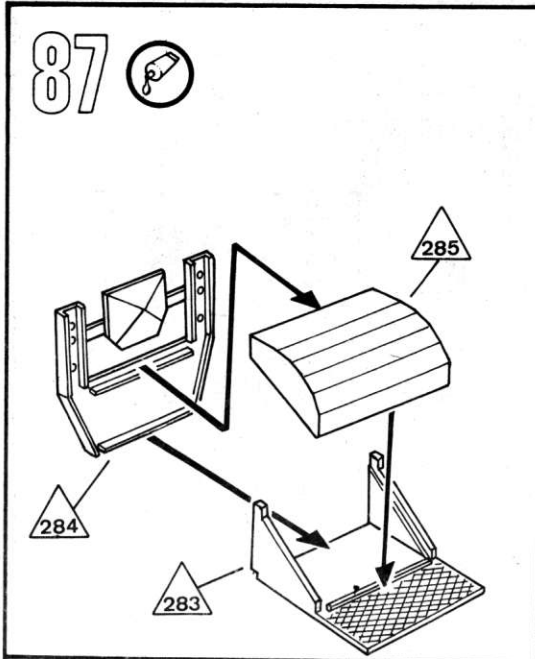

07522

92

